

APPLICATION PRINCIPLE

The static rod-locking device **with or without manual override** is fitted to series 450 and 453 PES type cylinders **with profiled barrel or tie-rods**. It is designed to hold the rod of the cylinder under load in the extended or retracted position in the event of air pressure or power failure during machine operation. The rod-locking device acts mechanically on the cylinder rod. It is unlocked when pressure is applied.

Advantages

- Easily accessible and quick-to-operate manual override (3/4 turn).
- Possibility of integrating the following options associated to the manual override:
 - Integrated rod-lock pilot control.
 - Detection (magnetic or electro-mechanical) of the position of the manual override.
 - Cylinder startup interlock system (Ø 80-100 mm).
- Simple adaption. The compactly sized rod-locking device has approximately the same dimensions of a standard cylinder.
- Possibility of mounting to specially designed cylinders (with overlength piston rod) complying with ISO 15552-AFNOR-DIN standards.
- Holding of the piston rod in the end-of-stroke position: with rod extended or rod retracted side.
- Holding in position of the maximum allowable cylinder load without creeping.
- Bi-directional action.
- Optional mounting position.

OPERATING PRINCIPLE

■ **NO PRESSURE ON STATIC ROD-LOCKING DEVICE (rod locked)**

No pressure is transmitted to the locking pistons (1). The springs (3) apply an axial force onto the two jaws (2) which clamp against the rod, holding it secure.

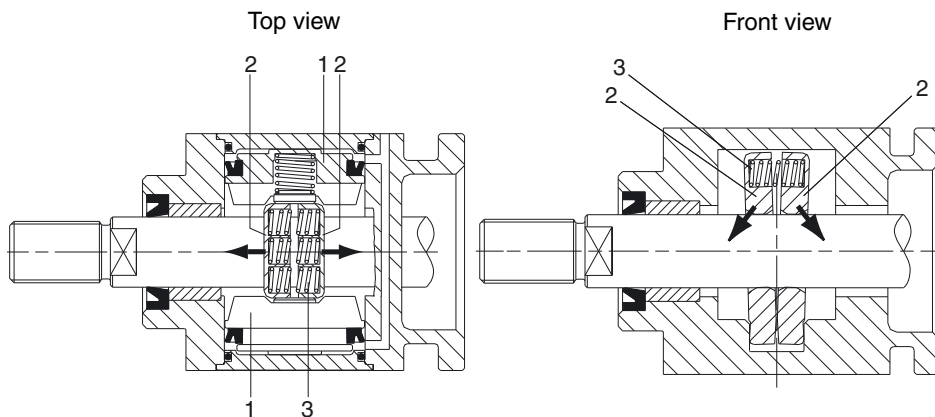

■ **STATIC ROD-LOCKING DEVICE UNDER PRESSURE (rod unlocked)**

The pressure exerts a force on the 2 pneumatic pistons (1) which come into contact with the two jaws (2), clamping them together. The 2 jaws no longer exert any force on the rod which is free to move.

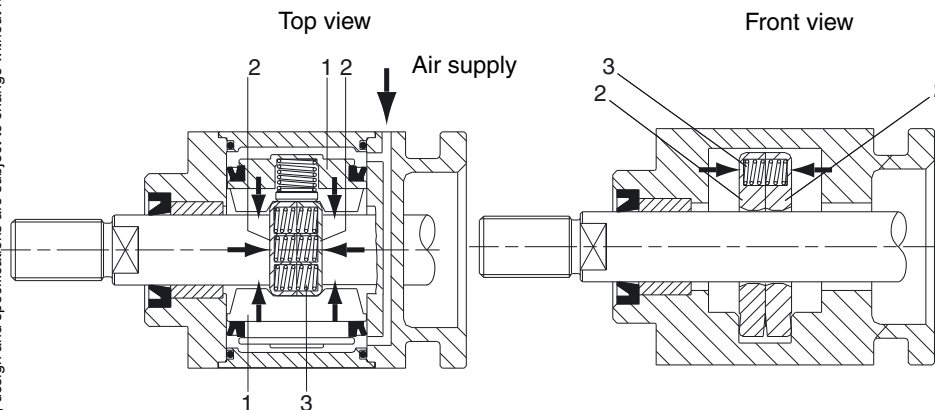

**OPERATING PRINCIPLE
OF THE
MANUAL OVERRIDE**

■ **NO PRESSURE ON STATIC ROD LOCK DEVICE (rod locked)**

Operate the manual override to disengage the rod.

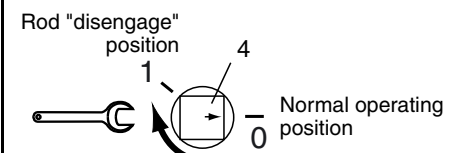
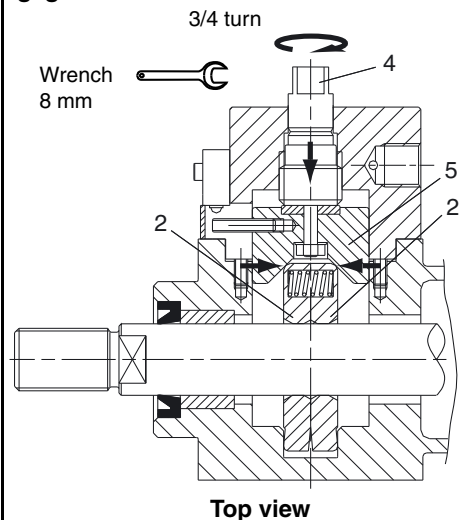

Actuating the manual override (4) by a 3/4 turn makes the piston (5) come into contact with the two jaws (2), clamping them together. The 2 jaws no longer exert any force on the rod which is unlocked.

Caution: After having operated the manual lock-up override, it must always be returned to its normal operating position (rod lock device "activated") by a trained and qualified person before starting up the system again.

THIS PRODUCT IS NOT A SAFETY COMPONENT

GENERAL SPECIFICATIONS

ASSEMBLY	: Rod lock device incorporated into cylinder, fitted in line, centered on the piston rod
CYLINDER	
CYLINDER TYPE	: Series 450-453 cylinder type PES conforming to ISO 15552-AFNOR NF ISO 15552-DIN ISO 15552 standards, aluminium barrel, adjustable pneumatic cushioning, designed for Reed switches, magneto-resistive or magneto-inductive position detectors.
CYLINDER BORE DIAMETERS	: Ø 32 - 40 - 50 - 63 - 80 - 100 mm.
STANDARD CYLINDER STROKES	: 50 to 600 mm (or more, consult us).
AMBIENT TEMPERATURE	: -20°C to +60°C
MOUNTING POSITION	: Optional, see assembly recommendations below.
MOUNTINGS	: All standard mountings for PES cylinders with tie-rods (see P229-18). Centre trunnion: consult us.

STATIC ROD LOCK DEVICE

FLUID	: Air or neutral gas, filtered, lubricated or unlubricated
PILOTING PRESSURE	: 6 bar
AMBIENT TEMPERATURE	: -5°C, +70°C
PNEUMATIC CONNECTION	: G1/8 (Ø32 - 63) - G1/4 (Ø 80 - 100)
MOUNTING POSITION	: Optional, see following pages for assembly recommendations.
STANDARDIZATIONS	: according to CNOMO RU-P/10 recommendation

MECHANICAL CHARACTERISTICS

HOLDING FORCES (static)	Ø 32 mm : 790 N	Ø 50 mm : 1930 N	Ø 80 mm : 5400 N
	Ø 40 mm : 1240 N	Ø 63 mm : 3060 N	Ø 100 mm : 7700 N

Example for holding force on a dia. 80 mm cylinder:

Attached weight (corresponding to a pressure of 6 bar and a 75 % load factor) = 2250 N

Additional force (equivalent to a pressure of 6 bar) = 3150 N

$$5400 \text{ N} = 2250 \text{ N} + 3150 \text{ N}$$

Holding force of rod lock device	Attached weight	Additional force
-------------------------------------	--------------------	------------------

CONSTRUCTION

Rod lock device without manual override

Rod lock device body	: Anodized aluminium
Piston	: Acetal resin
Seals	: Nitrile (NBR)



Rod lock device alone



Rod lock device pre-assembled on cylinder

Rod lock device with manual override

Rod lock device body	: Anodised aluminium
Piston	: Acetal resin
Seals	: Nitrile (NBR)
Override body	: Anodized aluminium

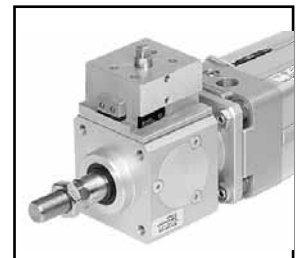

Rod lock device with manual override pre-assembled on cylinder

Integration possibilities: (see next page)

- Integrated rod-lock device pilot control.
- Integrated position detection (magnetic or electro-mechanical)
- Cylinder start-up interlock system

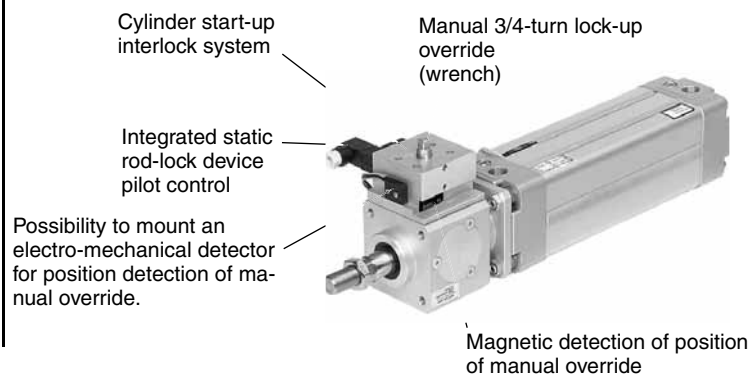

THIS PRODUCT IS NOT A SAFETY COMPONENT

CHOICE OF EQUIPMENT

When ordering, please specify:

- The code of the unit consisting of the CYLINDER + ROD-LOCKING DEVICE (**1**), the stroke and the following optional codes:
- INTEGRATED ROD-LOCKING DEVICE PILOT CONTROL (**2**)
- MOUNTINGS: The code(s) for the mountings and quantity (see P229-18) - Consult us for centre trunnion.
- DETECTORS ON CYLINDER: The codes of the magnetic position detectors which must be ordered separately:
 - "T" model (see page P291), reed switch or magneto-resistive type
 - "BIM" model, magneto-inductive (see page P297)

OR the codes for the rod-locking device alone (**3**) (if you wish to order it without a cylinder).

B

1 DEFINITION OF A CODE OF A UNIT CONSISTING OF CYLINDER + ROD-LOCKING DEVICE

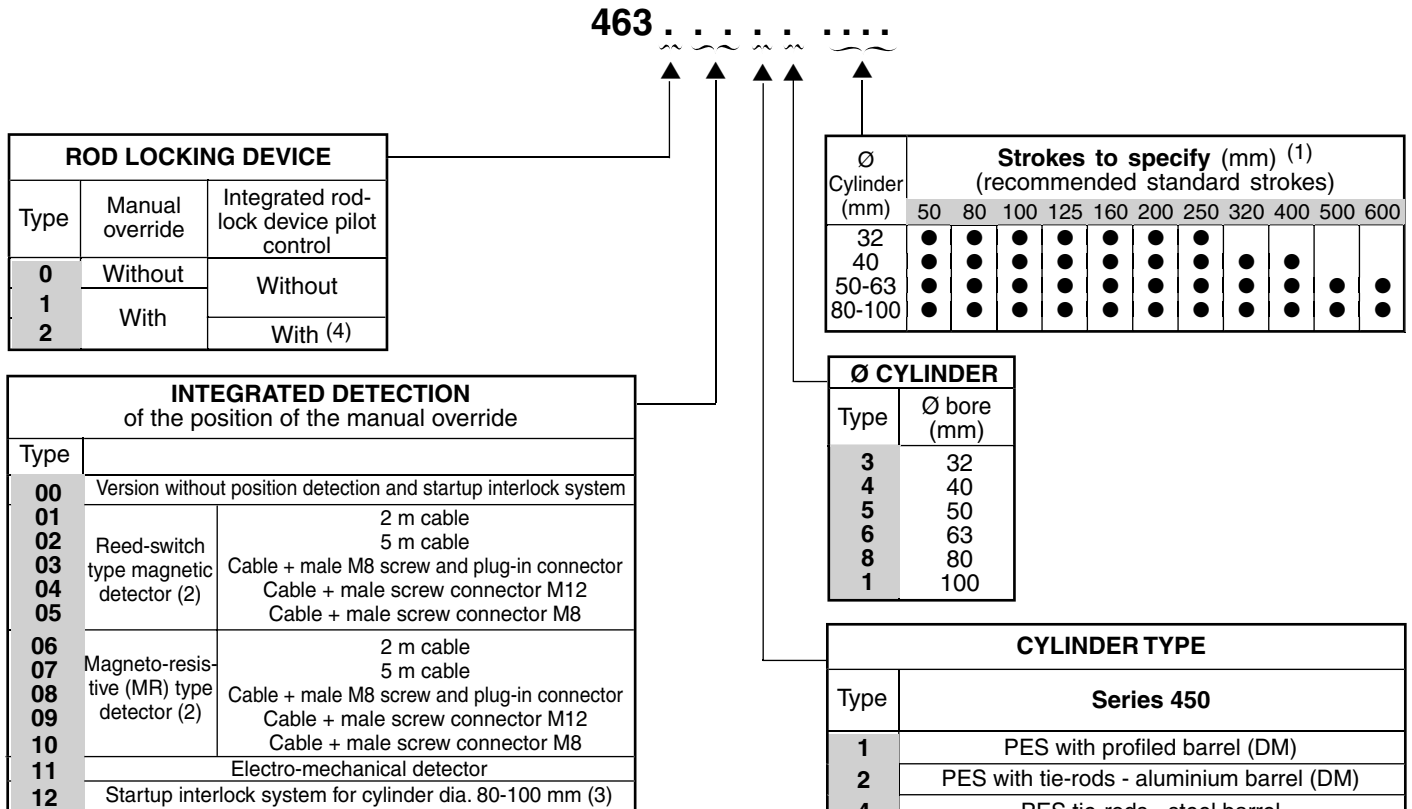

Ordering example for a unit:

- Rod-locking device with manual override and integrated rod-lock pilot control= **2**
- Reed-switch type detector with 2 m cable = **01**
- Cylinder type - PES series 453 with grooves, groove orientation at 12 o'clock position= **0**
- Cylinder dia. 80 mm = **8**
- Stroke 100 mm = **0100**

Ordering code: **463201080100** + solenoid valve code to order separately

- (1) Other strokes (consult us)
- (2) Characteristics: see P293
- (3) Micro-valve detection of the position of the manual lock-up override with autonomous air signal processing without PLC.
- (4) The solenoid valve must be ordered separately (see **2**)

*** POSITION OF THE T-SHAPED GROOVE**

The position of the T-shaped groove(s) is dependent on the axis of the supply ports of cylinder series 453. (see page P238-11)

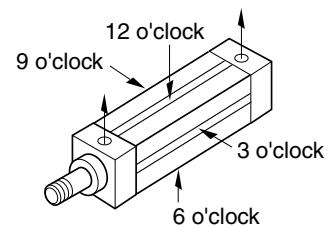

00241GB-2011/R01 Availability, design and specifications are subject to change without notice. All rights reserved.

2 INTEGRATED PILOT CONTROL FOR ROD-LOCKING DEVICE (to be ordered separately)

The rod-locking device can be actuated with a solenoid pilot valve with a mounting pad to ISO 15218 (CNOMO E06.36.120N, size 15) - see pilot valve series 302, page P502.

In order to prevent malfunction of the static rod-locking device, we recommended using series 302 pilot valves (without manual override or with impulse-type manual override).

3 ROD LOCK DEVICE ALONE (without manual override)

∅ cylinder (mm)	CODE ROD LOCK DEVICE alone
32	88145318
40	88145319
50	88145320
63	88145321
80	88145322
100	88145323

For all types of assembly (consult us)

CONNECTION OF ELECTRO-MECHANICAL DETECTOR

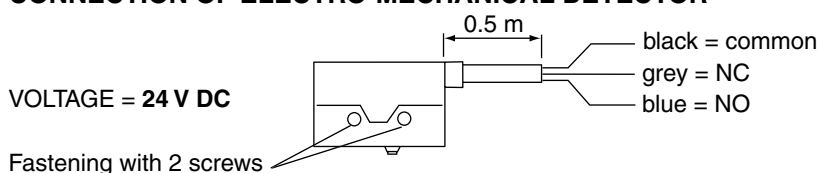

MOUNTING AND OPERATING RECOMMENDATIONS

Precautions should be taken when installing a cylinder fitted with a static rod-locking device. It is important to clearly define the type of layout that is required and the operating conditions of the cylinder.

The cylinder must be locked only in case of need at the end of a cycle in a situation such as:

- failure in electric supply;
- failure in pneumatic supply;
- drop in pressure.

The cylinder may be fitted horizontally or vertically, with the rod either upward or downward. It may also be tilted, with the rod either upward or downward.

A specific layout corresponds to each application. The specimen layouts on the opposite page show the principles to be observed and the stops caused by interruption of the power supply or removal of the pressure by means of electropneumatic valves.

In the case of a vertical movement of the load, the force on the piston which is generated by pressure - and which operates in the same direction as the load - must not exceed the locking capacity of the device when it is combined to the force of the load (see page 4).

After any emergency locking operation, make sure that the chambers of the cylinder are filled before the signal to unlock the device is given.

It is recommended to check the correct operation of the static rod-locking devices once a month:

- rod-lock system
- position detection system
- manual lock-up override mechanism
- pilot valve function

The following options and versions cannot be fitted to this cylinder with rod-locking device:

- Stainless steel piston rod
- Reinforced piston rod
- High temperature version
- Barrel in glass-fibre reinforced epoxy resin
- Anti-rotation device

MOUNTING OPTIONS

The cylinder is controlled by a 5/3 valve (ISO size 1 for diameters 32, 40 and 50 mm, ISO size 2 for diameters 63, 80 and 100 mm), with centre open to exhaust (type W3 - fig.1), and supplied by exhaust ports 3 and 5.

- NOTE:**
- 1) The static rod lock device must be activated by a 3/2 NC solenoid valve to ensure fast braking of the cylinder rod.
 - 2) It is recommended to use a pressure regulator to compensate for the cylinder's "rod effect".
 - 3) One-directional flow reducers must be used to control the rate of speed of the rod.

Safety precautions when using the manual override:

In case of air pressure or power failure, the rod-locking device holds the cylinder rod in place. The two cylinder chambers are exhausted. Only a trained and qualified person may unlock the rod (i.e. place the manual override in position 1: manual disengagement) and push the cylinder rod in the desired direction.

Caution:

Before starting up the cylinder again, the manual override must be returned to its normal operating position (position "0"). See cylinder startup interlock system designed for this purpose: Autonomous signal control without the use of a PLC.

B

HORIZONTAL MOUNTING

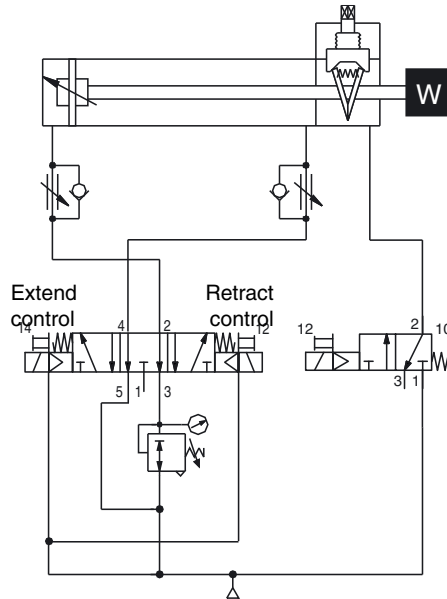

Fig. 1
Cylinder control with a 5/3 valve, centre open to exhaust (type W3)

VERTICAL MOUNTING

Caution:

In case the duly trained and qualified person wishes to operate the manual override (i.e. place it in position "1": manual disengagement), check the area underneath the load (fig. 2) or the area between the load and the cylinder nose (fig. 3) to make sure there is no hazard.

Fig. 2 - Load **underneath** the cylinder

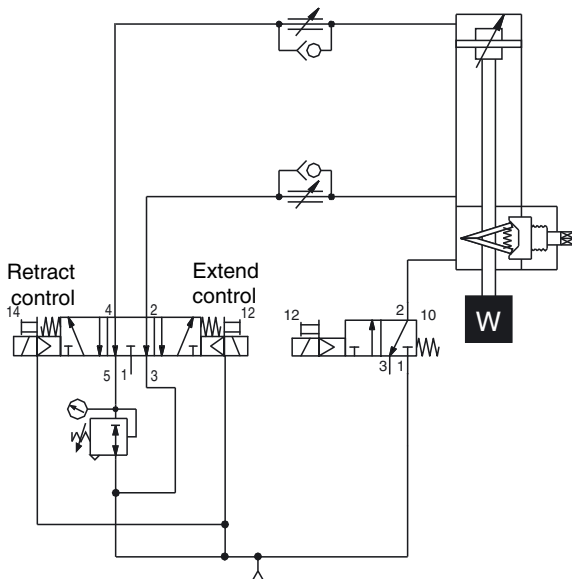
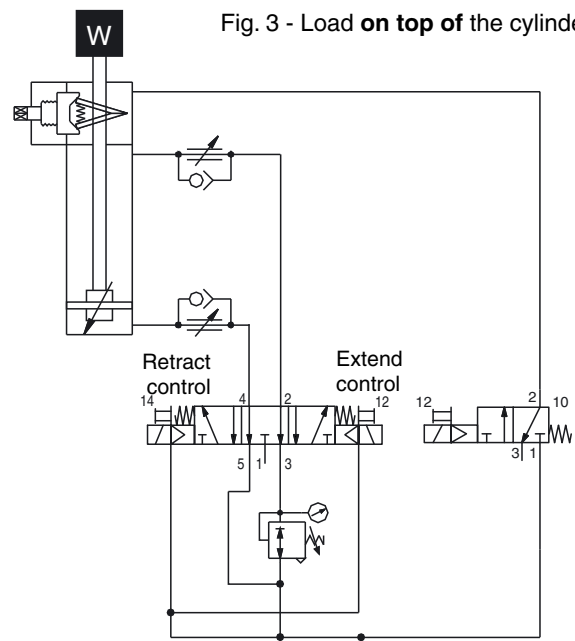

Fig. 3 - Load **on top of** the cylinder



00241GB-2010/R01
Availability, design and specifications are subject to change without notice. All rights reserved.

DIMENSIONS AND WEIGHTS

ROD-LOCKING DEVICE WITH MANUAL OVERRIDE ON A PES CYLINDER

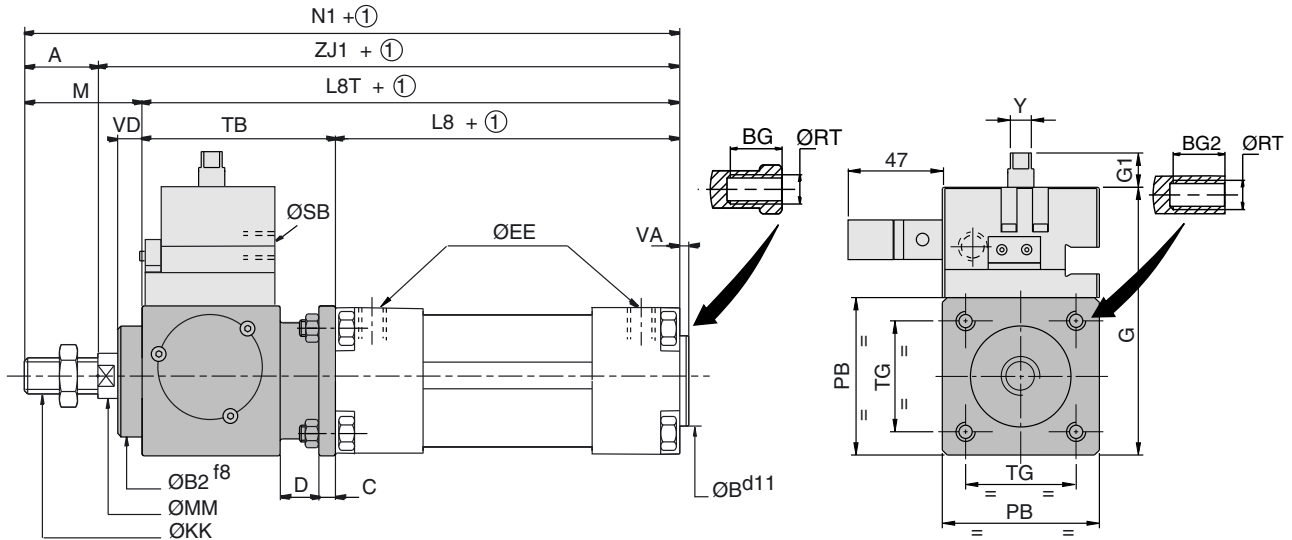

- Manual override with integrated rod-lock pilot control
- Static rod-locking device

ROD-LOCKING DEVICE WITHOUT MANUAL OVERRIDE ON A PES CYLINDER

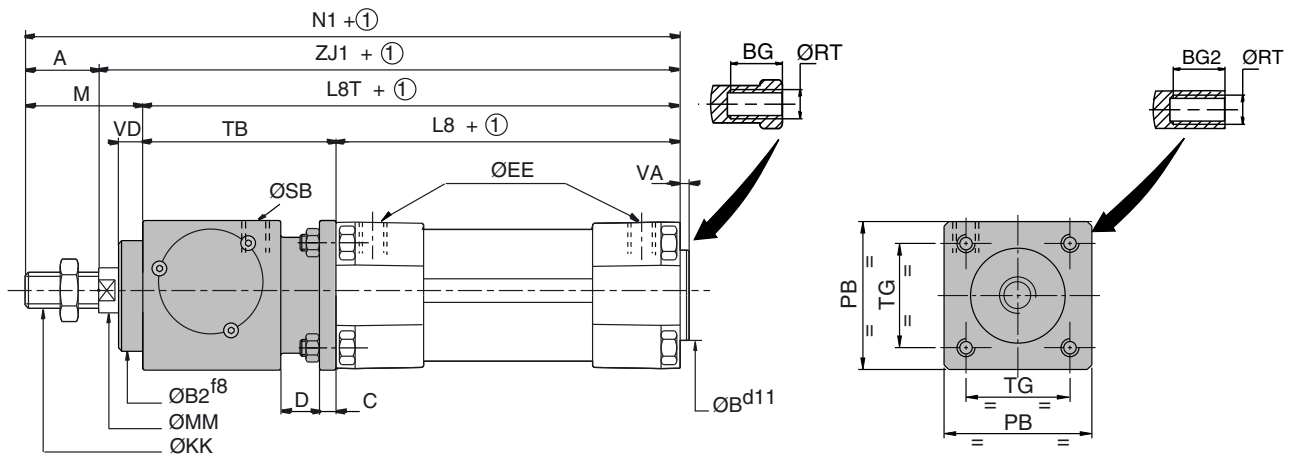

① : + stroke

Ø Cylinder (mm)	DIMENSIONS (mm)																		
	A	ØB2	ØB	BG	BG2	C	D	ØRT	ØEE	G	G1	ØKK	L8	L8T	M	ØMM	N1	PB	ØSB
32	22	30	30	16	8	6	20	M6	G1/8	79,5	11	M10x1,25	94	154	48	12	202	47	G1/8
40	24	34,9	35	16	8	6	20	M6	G1/4	85	11	M12x1,25	105	175	54	16	229	54	G1/8
50	32	40	40	16	12	8	24	M8	G1/4	107	14	M16x1,5	106	196	69	20	265	65	G1/8
63	32	45	45	16	12	8	24	M8	G3/8	113	14	M16x1,5	121	211	69	20	280	75	G1/8
80	40	45	45	17	16	12	32	M10	G3/8	138,5	14,5	M20x1,5	128	238	86	25	324	95	G1/4
100	40	55	55	17	16	12	32	M10	G1/2	155	14,5	M20x1,5	138	248	91	25	339	114	G1/4

Ø Cylinder (mm)	DIMENSIONS (mm)						Weight (kg) of the rod lock device alone with manual override	Weight (kg) of the rod lock device alone without manual override
	TB	TG	VA	VD	Y	ZJ1		
32	60	32,5	4	7,5	8	180	0,700	0,400
40	70	38	4	10	8	205	0,900	0,600
50	90	46,5	4	10	8	233	1,500	1,100
63	90	56,5	4	10	8	248	1,900	1,500
80	110	72	4	10	8	284	3,000	2,600
100	110	89	4	10	8	299	3,900	3,500

NOTE : The static rod-locking device is mounted in line and centered on the piston rod. Its outside dimensions are approximately equal to the standard dimensions of the cylinder. The lengths of the versions equipped with a static rod-locking device correspond to the standard lengths of the cylinders (see standard products) to which dimension TB is added.

Dimensions of mountings: see P229-18