

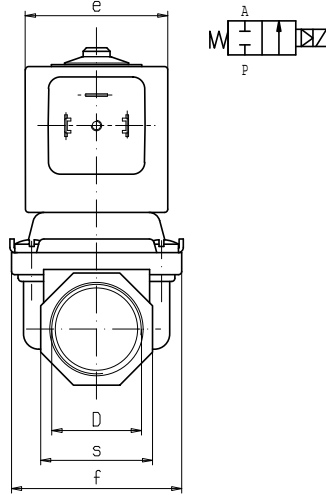

SOLENOID VALVE
2/2 - NC (Normally closed)
Pilot operated hung diaphragm
G3/8 ÷ 1

L133

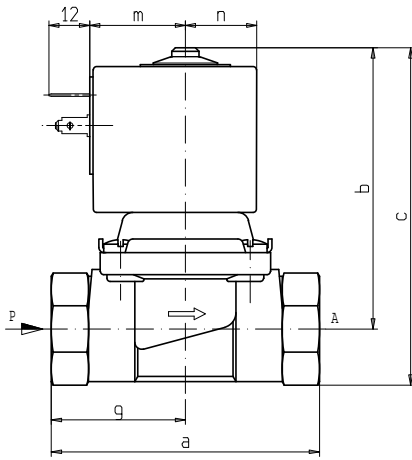

D	a	b	c	e	f	m	n	s	g
G 3/8	60	69	80	30	41	21,6	19,9	22	25,5
G 1/2	66	74,5	90	42	41	28	21	27	-
G 3/4	79	81	98	42	51	28	21	33	-
G 1	105	100	121	48,6	71	35	24,3	42	46

► GENERAL FEATURES

Pilot operated hung diaphragm valve with full orifice.
 Designed for closed circuit hydraulic systems and for vessels draining.
 Suitable to shut off liquid and gaseous fluids (verify the compatibility of fluid with materials in contact).

► TECHNICAL FEATURES

Maximum allowable pressure (PS) 16 bar
Opening time from ~100ms to ~150ms
Closing time from ~100ms to ~400ms
Fluid temperature -10°C +90°C (NBR)
 0°C +130°C (FPM)
Max viscosity 5°E (~37 cStokes or mm²/s)

► MATERIALS IN CONTACT WITH FLUID

Body Brass
Sealing NBR or FPM
Internal components Stainless steel and brass
Seat Brass
Core tube Stainless steel
Shading coil Copper

► COIL

Continuous duty ED 100%
Encapsulation material PET (polyethylene terephthalate) fiberglass reinforced
Insulation class F (140°C) on request class H (165°C) - UL
 ZA only: F (155°C) on request class H (180°C) - UL
Ambient temperature -10°C +60°C
 ZA only: -10°C +50°C
Electric connections DIN 46340 - 3 poles connectors (DIN 43650)
Protection degree IP 65 (EN 60529) with plug connector
Voltages DC 12-24V (+10% -5%)
AC 24V/50Hz - 110V/50Hz (120V/60Hz) - 230V/50Hz (+10% -15%)
 (Other voltages and frequencies on request)

Port size ISO 228	Orifice size (mm)	Differential pressure (bar)				Kv (m ³ /h)	Series and type		Power absorption			Sealings	Notes	Weight (kg)	
		Δp min	Δp max				Valve	Coil	AC (VA)		c.c. (W)				
			AC	DC	AC				DC	Inrush					Holding
G 3/8	10	0	10	3	10	3	L133B10	ZA30A	23	14	9	NBR	1	0,440	
	L133V10						FPM								
G 1/2	12,5		L133B07	Z130A	44	24	13	NBR							
	L133V07		FPM												
G 3/4	17		L133B07	Z923E	65	33	-	NBR							
	L133V07		FPM												
G 1	24	10	-	10	-	9	L133B06	Z923A	-	-	17	NBR	-	1,810	
		-	3	-	3		L133V06					FPM			
		-	-	-	-		L133B06					NBR			
							L133V06					FPM			

► NOTES

- Sealings : NBR = Nitrile-butylene elastomer FPM = Fluoro-carbon elastomer
 The nominal flow is guaranteed with Δp min ≥ 0,3 bar. Contact us in case of lower Δp min values.
 1 – The valves fitted with 50Hz coil can operate at 60 Hz but in this case the Δp max corresponds to the nominal value less 20%.

L133

► SPARE PARTS

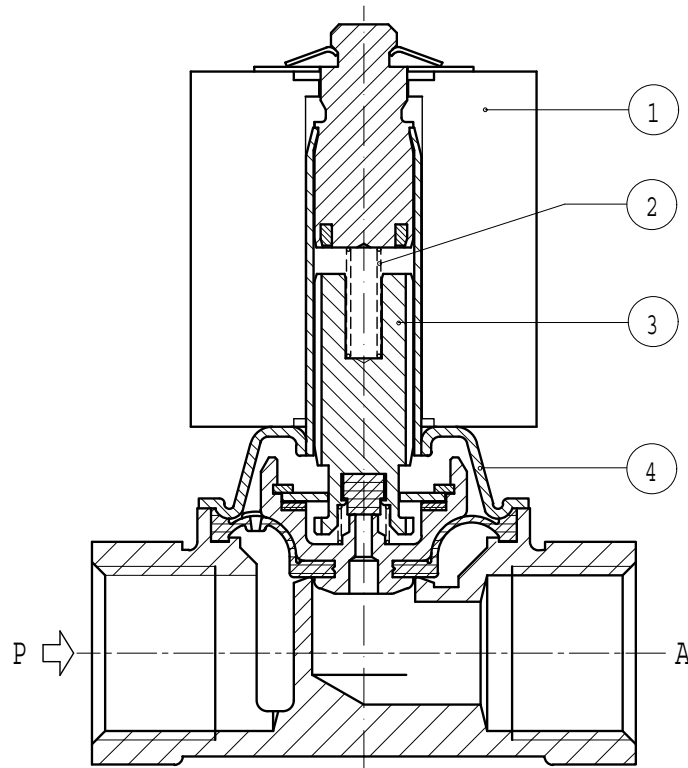

Kit description

Kit P.N.

Consisting of:

Core diaphragms kit	G 3/8	L133V10	G3104302	Core return spring pos.2 Diaphragm assembly with core assembly pos.3
	G 3/8	L133B10	G3104301	
	G 1/2	L133V07	G2990102	
	G 1/2	L133B07	G2990101	
	G 3/4	L133V07	G2990202	
	G 3/4	L133B07	G2990201	
	G 1	L133V06	G2991902	
	G 1	L133B06	G2991901	
Core return spring kit	G 3/8	L133B-V10	G3103701	n°10 core return springs pos. 2
	G 1/2	L133B-V07	G2139901	
	G 3/4	L133B-V07	G2918601	
	G 1	L133B-V06	G2955801	
Guide assembly	G 3/8	L133B-V10	3104101R	Guide assembly pos. 4
	G 1/2	L133B-V07	3077801R	
	G 3/4	L133B-V07	3077701R	
	G 1	L133B-V06	2408202R	
Coil	L133B-V10		ZA30A	Coil pos. 1
	L133B-V07		Z130A	
	L133B-V06 (DC)		Z923A	
	L133B-V06 (AC)		Z923E	

► INSTALLATION

Solenoid valve can be mounted in any position; vertical with coil upwards preferred.

THE VALIDITY OF REPORTED DATA IS REFERRED TO THE DATE OF ISSUE. POSSIBLE UPDATES ARE AVAILABLE ON REQUEST.