

# Compressed air maintenance unit, series AS2-Inch

Distributor block AS2-DIS, 3-way, 1/4 NPT - 3/8 NPT, ATEX approved



## Technical Data

Nominal flow qn	See table	
Secondary pressure = 91 psi and $\Delta p = 15$ psi		
Ambient temperature range	-10 °C to +50 °C (14 °F to 122 °F) *	
Medium	Compressed air	
Weight	See table	
Installation position	any	
Materials	Body Threaded insert Cover	Polyamide, seals Buna-N(NBR) Die cast Zinc ABS
ATEX:	In zone 1 (gas-ex, category 2G) In zone 21 (dust-ex, category 2D) In zone 2 (gas-ex, category 3G) In zone 22 (dust-ex, category 3D)	



Suitable for flange assembly of a mechanical vacuum/pressure switch

## Part no.

Symbol	Threaded ports	Nominal flow qn [CFM]	Weight [lbs]	Part no.
	1/4 NPT	95 (1- >2) <sup>1)</sup>	0.55	R432000658
	3/8 NPT	127 (1- >2) <sup>1)</sup>	0.55	R432000659

1) top (1- >5) = 70 CFM; front (1- >4) = 31 CFM; below (1- >3) = 70 CFM

## Accessories (to be ordered separately)

Accessory	Part no.
Mechanical vacuum switch, pabs = -13 ... 0 psi	0821100020
Mechanical pressure switch, p1 = 2 ... 43 psi	0821100021
Mechanical pressure switch, p1 = 15 ... 232 psi	0821100023
Block assembly kit AS2-MBR-...-W04	R412006371
Mounting strap AS2-MBR-...-W03	R412006370
Mounting plate AS2-MBR-...-W01	R432031071

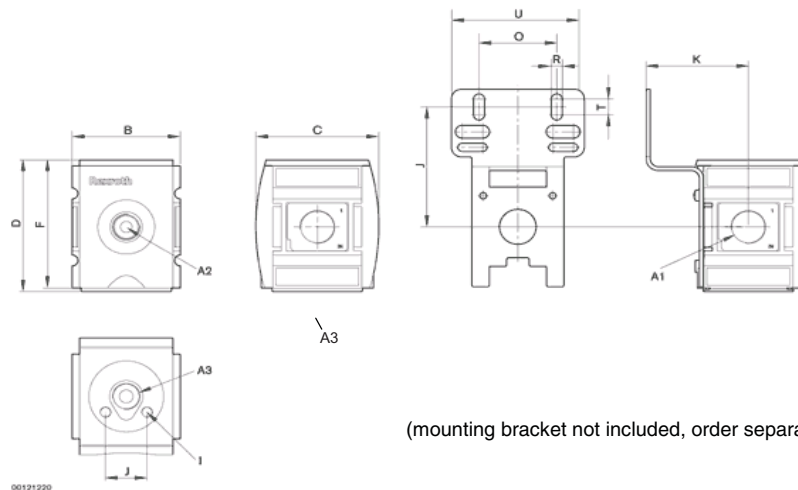

(mounting bracket not included, order separately)

A1	A2	A3	B	C	D	F	I	J	K	O	R	T	U
1/4 NPT	1/4 NPT	1/4 NPT	2.047	2.323	2.630	2.559	M5 (10-32)	0.787	1.945	1.496	0.213	0.394	2.559
3/8 NPT	1/4 NPT	1/4 NPT	2.047	2.323	2.630	2.559	M5 (10-32)	0.787	1.945	1.496	0.213	0.394	2.559

Dimensions in inches

Pneutrol International Limited  
UK Office  
5 Caulside Drive, Antrim, BT41 2DU  
United Kingdom  
TEL: +44 (0) 289448 1808  
www.valves-direct.com

sales@pneutrol.com  
European Office  
Unit 6, Saint Anthony's Business Park, Ballymount Road, D22 VW95  
Ireland  
TEL: +353 (0) 1 4373653  
www.valves-direct.com