

Compressed air maintenance unit, series AS2-Inch

Precision pressure regulator AS2-RGP, 1/4 NPT - 3/8 NPT,
ATEX approved

AVENTICS®



Technical Data

| | | |
|---|--|--|
| Type | Diaphragm-type pressure regulator with relief opening and reverse flow capability Lockable regulator knob | |
| Supply pressure | 232 psi (max.) | |
| Secondary pressure | See table | |
| Nominal flow qn | See table | |
| Secondary pressure = 91 psi and Δp = 15 psi | | |
| Temperature range | -10 °C to +50 °C (14 °F to +122 °F) * | |
| Medium | Compressed air | |
| Weight | See table | |
| Installation position | Any | |



| | | |
|-----------|--------------------------------|--|
| Materials | Body Thread insert Cover | Polyamide, seals Buna-N(NBR) Die-cast zinc ABS |
|-----------|--------------------------------|--|

| | |
|-------|--|
| ATEX: | In zone 1 (gas-ex, category 2G) In zone 21 (dust-ex, category 2D) In zone 2 (gas-ex, category 3G) In zone 22 (dust-ex, category 3D) |
|-------|--|

* with dried air
Continuous air consumption qn = 0.09 CFM, depends on secondary pressure p2 = 87 psi

Part no.

| Symbol | Threaded ports | Nominal flow qn [CFM] | Secondary pressure [psi] | Weight [lbs] | Part no. with pressure gauge |
|--------|----------------|-----------------------|--------------------------|--------------|------------------------------|
| | 1/4 NPT | 78 | 1 ... 14 | 0.71 | R432000597 |
| | 1/4 NPT | 78 | 1 ... 29 | 0.71 | R432000599 |
| | 1/4 NPT | 78 | 2 ... 58 | 0.71 | R432000601 |
| | 1/4 NPT | 78 | 7 ... 116 | 0.71 | R432000603 |
| | 1/4 NPT | 78 | 7 ... 145 | 0.71 | R432000605 |
| | 3/8 NPT | 95 | 1 ... 14 | 0.71 | R432000607 |
| | 3/8 NPT | 95 | 1 ... 29 | 0.71 | R432000609 |
| | 3/8 NPT | 95 | 2 ... 58 | 0.71 | R432000611 |
| | 3/8 NPT | 95 | 7 ... 116 | 0.71 | R432000613 |
| | 3/8 NPT | 95 | 7 ... 145 | 0.71 | R432000615 |

Part no.

| Symbol | Threaded ports | Nominal flow qn [CFM] | Secondary pressure [psi] | Weight [lbs] | Part no. without pressure gauge |
|--------|----------------|-----------------------|--------------------------|--------------|---------------------------------|
| | 1/4 NPT | 78 | 1 ... 14 | 0.55 | R432000596 |
| | 1/4 NPT | 78 | 1 ... 29 | 0.55 | R432000598 |
| | 1/4 NPT | 78 | 2 ... 58 | 0.55 | R432000600 |
| | 1/4 NPT | 78 | 7 ... 116 | 0.55 | R432000602 |
| | 1/4 NPT | 78 | 7 ... 145 | 0.55 | R432000604 |
| | 3/8 NPT | 95 | 1 ... 14 | 0.55 | R432000606 |
| | 3/8 NPT | 95 | 1 ... 29 | 0.55 | R432000608 |
| | 3/8 NPT | 95 | 2 ... 58 | 0.55 | R432000610 |
| | 3/8 NPT | 95 | 7 ... 116 | 0.55 | R432000612 |
| | 3/8 NPT | 95 | 7 ... 145 | 0.55 | R432000614 |

Accessories (to be ordered separately)

| | Accessory | Part no. |
|--|------------------------------------|------------|
| | Pressure regulator valve seal kit | R961400031 |
| | Mounting plate AS2-MBR-...-W01 | R432031071 |
| | Mounting strap AS2-MBR-...-W03 | R412006370 |
| | Block assembly kit AS2-MBR-...-W04 | R412006371 |

See accessories section for pressure gauges

Pneutrol International Limited
UK Office
5 Caulside Drive, Antrim, BT41 2DU
United Kingdom
TEL: +44 (0) 289448 1808
www.valves-direct.com

sales@pneutrol.com
European Office
Unit 6, Saint Anthony's Business Park, Ballymount Road, D22 VW95
Ireland
TEL: +353 (0) 1 4373653
www.valves-direct.com

Compressed air maintenance unit, series AS2-Inch

Precision pressure regulator AS2-RGP, 1/4 NPT - 3/8 NPT,
ATEX approved



Pressure characteristics curve

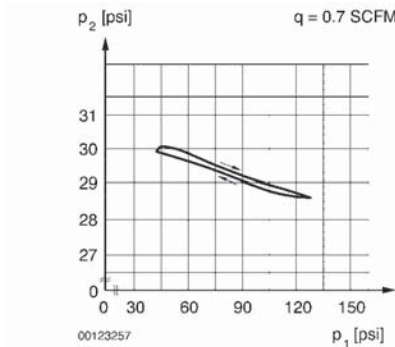

p_1 = Supply pressure; p_2 = Secondary pressure; q_n = Flow rate

Flow rate characteristic (setting range p_2 : 7 to 116 psi)

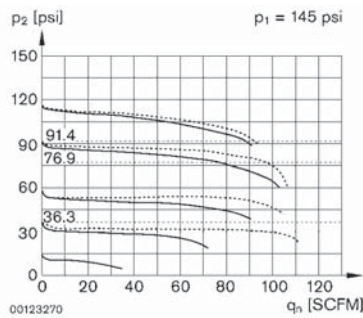

p_1 = Supply pressure; p_2 = Secondary pressure; q_n = Nominal flow

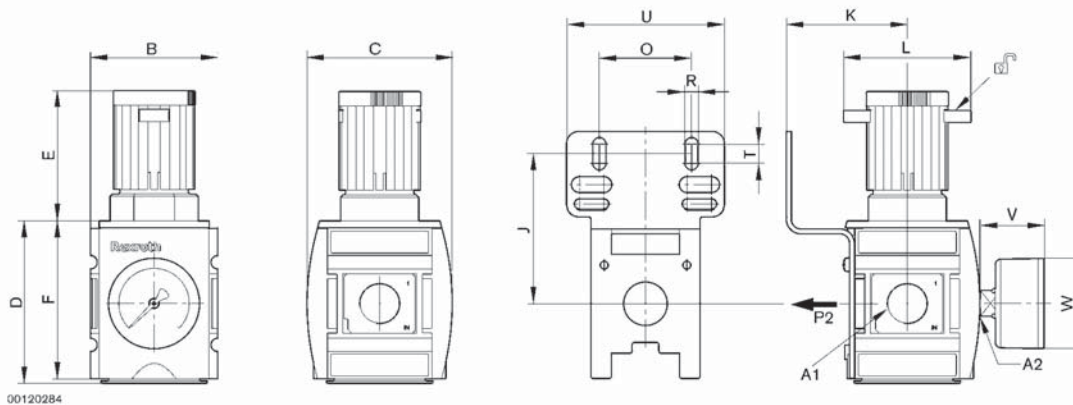

(mounting bracket not included, order separately)

| A1 | A2 | B | C | D | E | F | J | K | L | O | R | T | U | V | W |
|---------|---------|-------|-------|-------|-------|-------|-------|-------|-------|-------|-------|-------|-------|-------|---|
| 1/4 NPT | 1/4 NPT | 2.047 | 2.323 | 2.630 | 2.094 | 2.559 | 2.433 | 1.945 | 2.047 | 1.496 | 0.213 | 0.394 | 2.559 | 1.378 | 2 |
| 3/8 NPT | 1/4 NPT | 2.047 | 2.323 | 2.630 | 2.094 | 2.559 | 2.433 | 1.945 | 2.047 | 1.496 | 0.213 | 0.394 | 2.559 | 1.378 | 2 |

Dimensions in inches

Pneutrol International Limited
UK Office
5 Caulside Drive, Antrim, BT41 2DU
United Kingdom
TEL: +44 (0) 289448 1808
www.valves-direct.com

sales@pneutrol.com
European Office
Unit 6, Saint Anthony's Business Park, Ballymount Road, D22 VW95
Ireland
TEL: +353 (0) 1 4373653
www.valves-direct.com