

Compressed air maintenance unit, series AS3-Inch

Precision pressure regulator AS3-RGP, 3/8 NPT - 1/2 NPT,
ATEX approved

AVENTICS®



Technical Data

Type	Diaphragm-type pressure regulator with relief opening and reverse flow capability Lockable regulator knob	
Supply pressure	232 psi	
Secondary pressure	See table	
Nominal flow Qn	See table	
Secondary pressure = 91 psi and Δp = 15 psi		
Temperature range	-10 to +50 °C (14 °F to +122 °F) *	
Medium	Compressed air	
Weight	See table	
Installation position	Any	
Materials	Body Thread insert Cover	Polyamide, seals Buna-N(NBR) Die-cast zinc ABS



* with dried air
Continuous air consumption = 0.09 CFM, depending on secondary
pressure p2 = 87 psi

ATEX	In zone 1 (gas-ex, category 2G) In zone 21 (dust-ex, category 2D) In zone 2 (gas-ex, category 3G) In zone 22 (dust-ex, category 3D)
------	--

Part no.

Symbol	Threaded ports	Nominal flow Qn [CFM]	Secondary pressure [psi]	Weight [lbs.]	Part no. with pressure gauge
	3/8 NPT	58	1 ... 14	1.323	R432001957
	3/8 NPT	162	1 ... 29	1.323	R432001959
	3/8 NPT	178	2 ... 58	1.323	R432001961
	3/8 NPT	151	7 ... 116	1.323	R432001963
	3/8 NPT	151	7 ... 145	1.323	R432001965
	1/2 NPT	58	1 ... 14	1.323	R432001967
	1/2 NPT	162	1 ... 29	1.323	R432001969
	1/2 NPT	176	2 ... 58	1.323	R432001971
	1/2 NPT	183	7 ... 116	1.323	R432001973
	1/2 NPT	183	7 ... 145	1.323	R432001975

Part no.

Symbol	Threaded ports	Nominal flow Qn [CFM]	Secondary pressure [psi]	Weight [lbs.]	Part no. without pressure gauge
	3/8 NPT	58	1 ... 14	1.164	R432001956
	3/8 NPT	162	1 ... 29	1.164	R432001958
	3/8 NPT	178	2 ... 58	1.164	R432001960
	3/8 NPT	151	7 ... 116	1.164	R432001962
	3/8 NPT	151	7 ... 145	1.164	R432001964
	1/2 NPT	58	1 ... 14	1.164	R432001966
	1/2 NPT	162	1 ... 29	1.164	R432001968
	1/2 NPT	176	2 ... 58	1.164	R432001970
	1/2 NPT	183	7 ... 116	1.164	R432001972
	1/2 NPT	183	7 ... 145	1.164	R432001974

Accessories (to be ordered separately)

	Accessory	Part no.
	Pressure regulator valve seal kit	R961400145
	Mounting plate AS3-MBR-...-W01	R432031072
	Mounting strap AS3-MBR-...-W03	R412007370
	Block assembly kit AS3-MBR-...-W04	R412007371
	Mounting flange kit (3/8 inch) AS3-MBR-N038...-W05	R432002017
	Mounting flange kit (1/2 inch) AS3-MBR-N012...-W05	R432002018
	Control panel nut AS3-MBR-...-W06	R412007372

Pneutrol International Limited
UK Office
5 Caulside Drive, Antrim, BT41 2DU
United Kingdom
TEL: +44 (0) 289448 1808
www.valves-direct.com

sales@pneutrol.com
European Office
Unit 6, Saint Anthony's Business Park, Ballymount Road, D22 VW95
Ireland
TEL: +353 (0) 1 4373653
www.valves-direct.com

Compressed air maintenance unit, series AS3-Inch

Precision pressure regulator AS3-RGP, 3/8 NPT - 1/2 NPT,
ATEX approved



Pressure characteristics curve

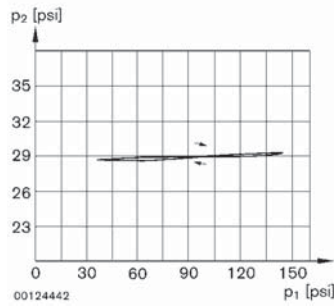

p_1 = Supply pressure; p_2 = Secondary pressure; q = Flow rate

Flow rate characteristic (setting range p_2 : 7 ... 116 psi)

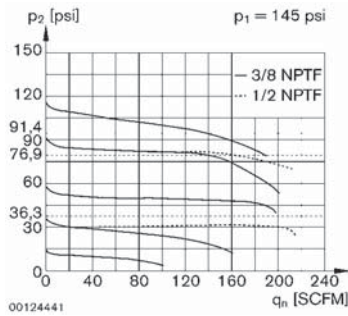

p_1 = Supply pressure; p_2 = Secondary pressure; q_n = Nominal flow

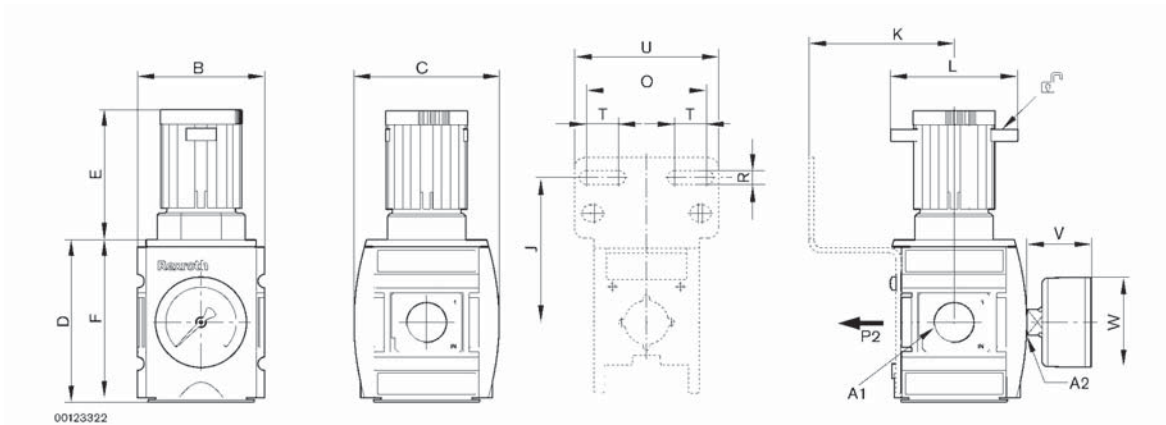

A1	A2	B	C	D	E	F	J	K	L	O	R	T	U	V	W
3/8 NPT	1/4 NPT	2.480	2.913	3.228	2.500	3.150	2.854	2.795	2.323	2.362	0.276	0.630	2.835	1.378	1.969
1/2 NPT	1/4 NPT	2.480	2.913	3.228	2.500	3.150	2.854	2.795	2.323	2.362	0.276	0.630	2.835	1.378	1.969

Dimensions in inches

Pneutrol International Limited
UK Office
5 Caulside Drive, Antrim, BT41 2DU
United Kingdom
TEL: +44 (0) 289448 1808
www.valves-direct.com

sales@pneutrol.com
European Office
Unit 6, Saint Anthony's Business Park, Ballymount Road, D22 VW95
Ireland
TEL: +353 (0) 1 4373653
www.valves-direct.com