

Distributor, Series AS2-DIC

- G 3/8
- Distributor 3x
- Center infeed
- suitable for ATEX



Version	Center infeed, Can be assembled into blocks
Parts	Distributor
Mounting orientation	Any
Certificates	suitable for ATEX
Working pressure min./max.	0 ... 16 bar
Ambient temperature min./max.	-10 ... 50 °C
Medium temperature min./max.	-10 ... 50 °C
Medium	Compressed air Neutral gases
Weight	0,648 kg

Technical data



Part No.	Port	Nominal flow	Nominal flow	Nominal flow	Nominal flow
		Qn 1►2	Qn 1►3	Qn 1►4	Qn 1►5
R412006249	G 3/8	2700 l/min	2000 l/min	900 l/min	2000 l/min

Technical information

Suitable for direct mounting of a PE1 and PM1 series pressure sensor (flange version)
Additional air supply possible at connections A4 and A5.
Suitable for use in Ex zones 1, 2, 21, 22

Technical information

Material	
Housing	Polyamide
Front plate	Acrylonitrile butadiene styrene
Seals	Acrylonitrile butadiene rubber
Threaded bushing	Die cast zinc

Dimensions

Dimensions

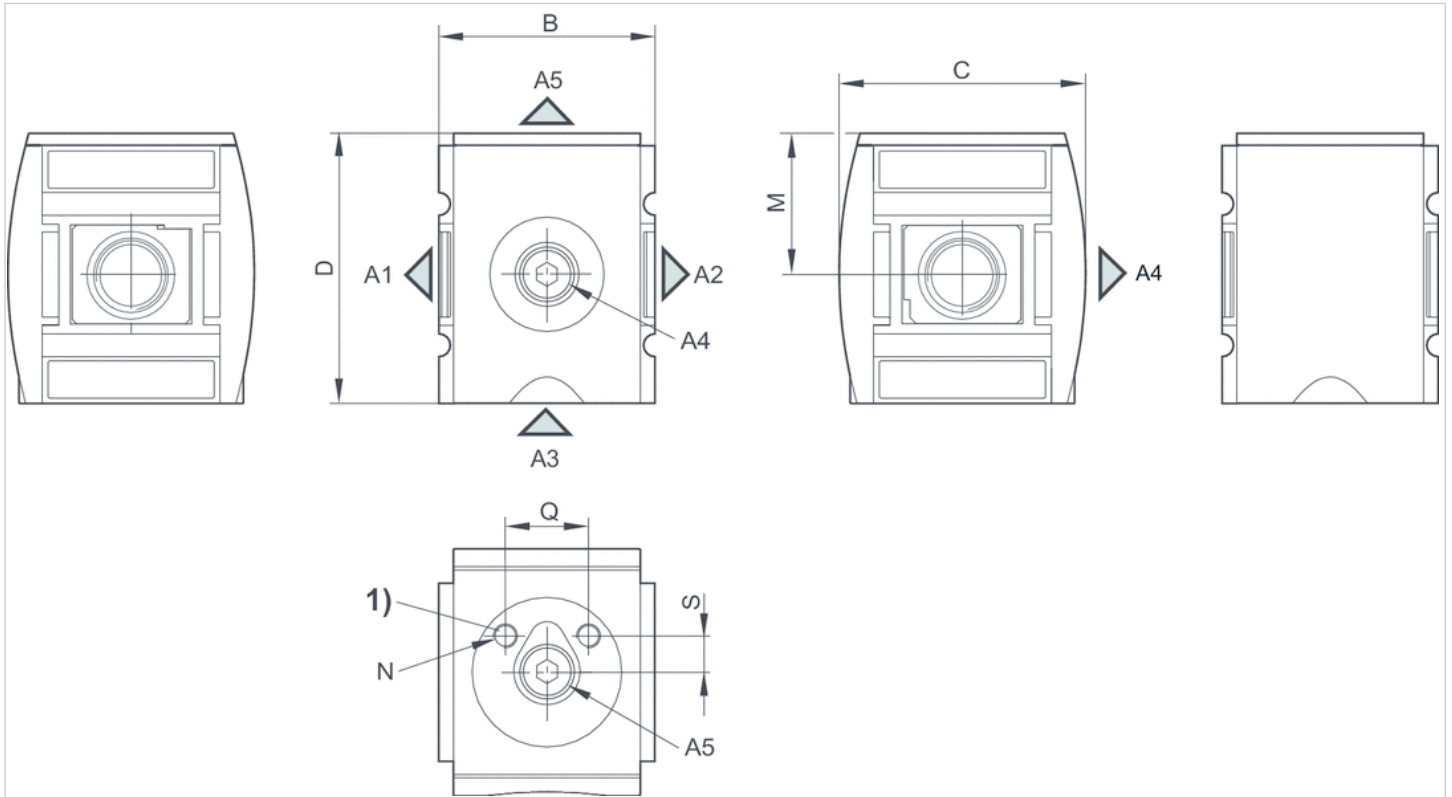

A1 = output A2 = output A3 = input/output A4 = output A5 = input/output
1) Mounting thread for pressure sensor

Dimensions in mm

A1	A2	A3	A4	A5	B	C	D	M	N	Q	S
G 3/8	G 3/8	G 1/4	G 1/4	G 1/4	52	59	65	32.5	M5	20	8