

# Maintenance unit, 3-part, Series AS3- ACT

- G 3/8
- filter porosity 5  $\mu\text{m}$
- lockable
- for padlocks
- with pressure gauge
- suitable for ATEX

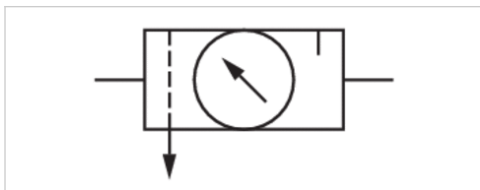

Version	3-part, Can be assembled into blocks
Parts	Pressure regulator, Filter, Lubricator
Mounting orientation	vertical
Certificates	suitable for ATEX
Working pressure min./max.	See table
Ambient temperature min./max.	-10 ... 50 °C
Medium temperature min./max.	-10 ... 50 °C
Medium	Compressed air Neutral gases
Nominal flow Qn	3500 l/min
Regulator type	Diaphragm-type pressure regulator
Regulator function	with relieving air exhaust
Adjustment range min./max.	0,5 ... 8 bar
Pressure supply	single
Filter reservoir volume	49 cm <sup>3</sup>
Filter element	exchangeable
Condensate drain	See table
Lubricator reservoir volume	80 cm <sup>3</sup>
Type of filling	Semi-automatic oil filling during operation Manual oil filling
Weight	See table

## Technical data

Part No.	Port	Flow	Working pressure min./max.
		Qn	
R412007318	G 3/8	3500 l/min	1,5 ... 16 bar
R412007319	G 3/8	3500 l/min	1,5 ... 16 bar
R412007320	G 3/8	3500 l/min	0 ... 16 bar
R412007324	G 3/8	3500 l/min	1,5 ... 16 bar
R412007325	G 3/8	3500 l/min	1,5 ... 16 bar
R412007326	G 3/8	3500 l/min	0 ... 16 bar
R412007327	G 1/2	3500 l/min	1,5 ... 16 bar
R412007328	G 1/2	3500 l/min	1,5 ... 16 bar
R412007329	G 1/2	3500 l/min	0 ... 16 bar
R412007333	G 1/2	3500 l/min	1,5 ... 16 bar
R412007334	G 1/2	3500 l/min	1,5 ... 16 bar
R412007335	G 1/2	3500 l/min	0 ... 16 bar

Part No.	Condensate drain	Reservoir	Protective guard	Weight
R412007318	semi-automatic, open without pressure	Polycarbonate	Polyamide	1,35 kg
R412007319	fully automatic, open without pressure	Polycarbonate	Polyamide	1,4 kg
R412007320	fully automatic, closed without pressure	Polycarbonate	Polyamide	1,4 kg
R412007324	semi-automatic, open without pressure	Die cast zinc	-	2,41 kg
R412007325	fully automatic, open without pressure	Die cast zinc	-	2,43 kg
R412007326	fully automatic, closed without pressure	Die cast zinc	-	2,44 kg
R412007327	semi-automatic, open without pressure	Polycarbonate	Polyamide	1,35 kg
R412007328	fully automatic, open without pressure	Polycarbonate	Polyamide	1,4 kg
R412007329	fully automatic, closed without pressure	Polycarbonate	Polyamide	1,4 kg
R412007333	semi-automatic, open without pressure	Die cast zinc	-	2,34 kg
R412007334	fully automatic, open without pressure	Die cast zinc	-	2,37 kg
R412007335	fully automatic, closed without pressure	Die cast zinc	-	2,39 kg

## Technical information

The pressure dew point must be at least 15 °C under ambient and medium temperature and may not exceed 3 °C .

Note: Polycarbonate reservoirs are susceptible to solvents, supplementary information can be found at "Customer information".

Suitable for use in Ex zones 1, 2, 21, 22

A change in the flow direction (from air supply on the left to air supply on the right) occurs by rotating installation by 180° about the vertical axis. Please see the operating instructions for further details.

Also suitable for separation of fluid oil or water due to the design.

## Technical information

Material	
Housing	Polyamide
Front plate	Acrylonitrile butadiene styrene
Seals	Acrylonitrile butadiene rubber
Threaded bushing	Die cast zinc
Reservoir	Polycarbonate Die cast zinc
Protective guard	Polyamide
Filter insert	Polyethylene

# Dimensions

## Dimensions

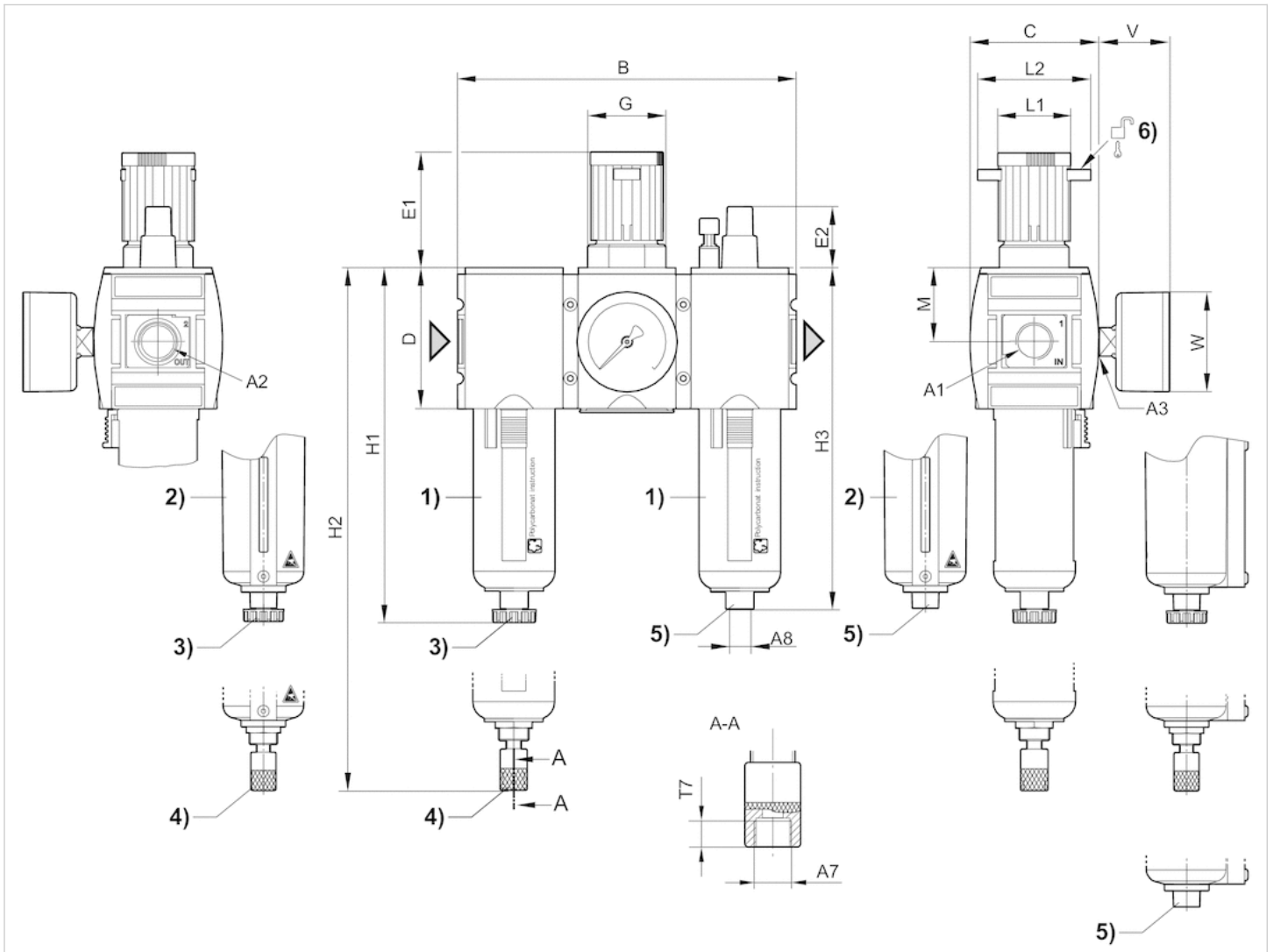

- A1 = input
- A2 = output
- A3 = pressure gauge connection
- A7 = condensate drain
- 1) Plastic reservoir and protective guard with window
- 2) Metal reservoir with level indicator
- 3) Semi-automatic condensate drain
- 4) Fully automatic condensate drain
- 5) Port for semi-automatic oil filling
- 6) Mounting option for padlocks; max. shackle Ø 8

## Dimensions in mm

A1	A2	A3	A7	A8	B	C	D	E1	E2	G	H1	H2	H3	M	L1	L2	T7	V	W
G 3/8	G 3/8	G 1/4	G 1/8	G 1/8	189	74	80	63.5	27.5	M42x1,5	189.5	206	183	42.5	41	60	8.5	33	50
G 3/8	G 3/8	G 1/4	G 1/8	G 1/8	189	74	80	63.5	27.5	M42x1,5	189.5	206	183	42.5	41	60	8.5	33	50
G 1/2	G 1/2	G 1/4	G 1/8	G 1/8	189	74	80	63.5	27.5	M42x1,5	189.5	206	183	42.5	41	60	8.5	33	50

## Diagrams

### Lubricator activation margin

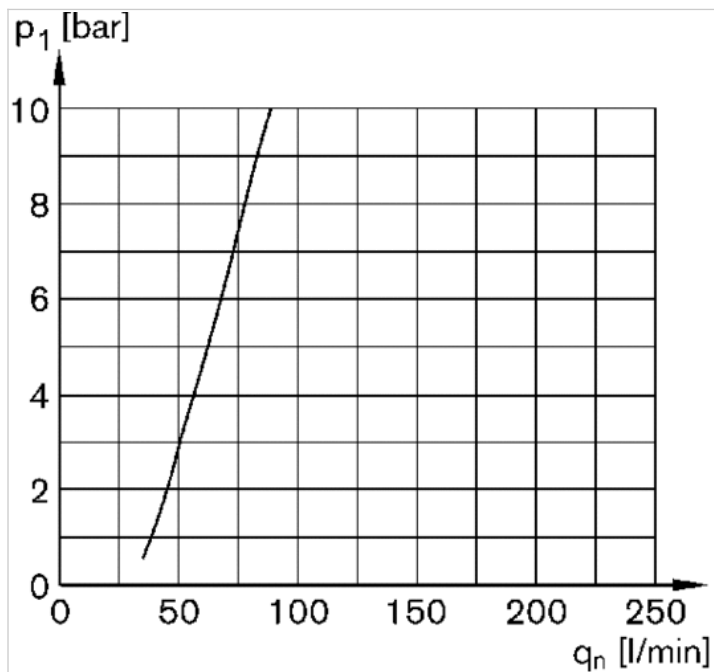

p1 = working pressure  
qn = nominal flow

### Flow rate characteristic (p2: 0.5 - 8 bar)

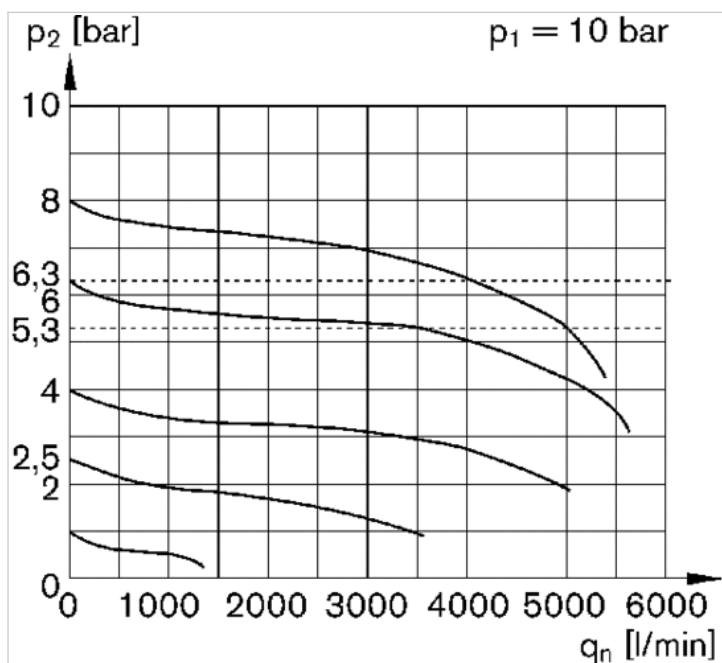

p1 = Working pressure  
p2 = Secondary pressure  
qn = Nominal flow