

Filter, Series NL1-FLS

- G 1/8
- filter porosity 5 µm
- suitable for ATEX



Version	Standard filter, Can be assembled into blocks
Parts	Filter
Mounting orientation	vertical
Certificates	suitable for ATEX
Working pressure min./max.	1,5 ... 16 bar
Ambient temperature min./max.	-10 ... 60 °C
Medium temperature min./max.	-10 ... 60 °C
Medium	Compressed air Neutral gases
Filter reservoir volume	16 cm ³
Filter element	exchangeable
filter porosity	5 µm
Condensate drain	See table
Weight	See table

Technical data

Part No.	Port	Qn	Condensate drain	Reservoir
0821303710	G 1/8	1000 l/min	semi-automatic, open without pressure	Polycarbonate
0821303711	G 1/8	1000 l/min	semi-automatic, open without pressure	Die cast zinc
0821303712	G 1/8	1000 l/min	fully automatic, open without pressure	Polycarbonate
0821303713	G 1/4	1000 l/min	semi-automatic, open without pressure	Polycarbonate
0821303714	G 1/4	1000 l/min	semi-automatic, open without pressure	Die cast zinc
0821303715	G 1/4	1000 l/min	fully automatic, open without pressure	Polycarbonate

Part No.	Weight
0821303710	0,334 kg
0821303711	0,259 kg
0821303712	0,263 kg
0821303713	0,21 kg
0821303714	0,259 kg
0821303715	0,263 kg

Technical information

The pressure dew point must be at least 15 °C under ambient and medium temperature and may not exceed 3 °C .

Suitable for use in Ex zones 1, 2, 21, 22

Note: Polycarbonate reservoirs are susceptible to solvents, supplementary information can be found at "Customer information".

A change in the flow direction (from air supply on the left to air supply on the right) occurs by rotating installation by 180° about the vertical axis. Please see the operating instructions for further details.

Also suitable for separation of fluid oil or water due to the design.

Max. achievable compressed air class acc. to ISO 8573-1:2010 6 : 7 : -

Technical information

Material	
Housing	Die cast zinc
Seals	Acrylonitrile butadiene rubber
Reservoir	Polycarbonate Die cast zinc
Filter insert	Cellpor

Dimensions

Dimensions

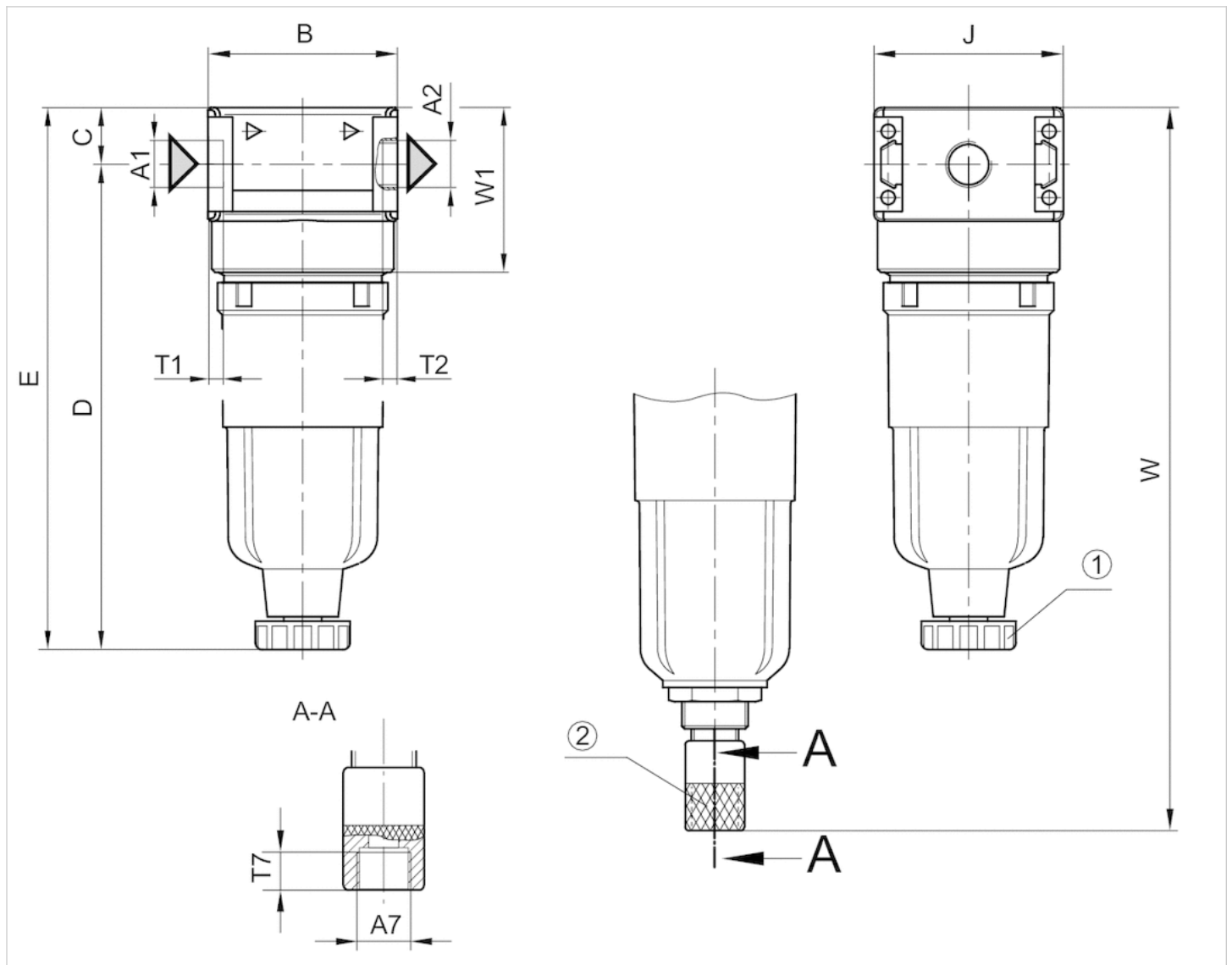

A1 = input A2 = output

1) Semi-automatic condensate drain 2) fully automatic condensate drain

Dimensions in mm

A1	A2	A7	B	C	D	E	J	T1	T2	T7	W	W1
G 1/8	G 1/8	G 1/8	40	12.3	102.5	114.8	40	8	8	8.5	-	35.1
G 1/8	G 1/8	G 1/8	40	12.3	-	114	40	8	8	8.5	-	35.1
G 1/8	G 1/8	G 1/8	40	12.3	-	-	40	8	8	8.5	154	35.1
G 1/4	G 1/4	G 1/8	40	12.3	102.5	114.8	40	8	8	8.5	-	35.1
G 1/4	G 1/4	G 1/8	40	12.3	-	114	40	8	8	8.5	-	35.1
G 1/4	G 1/4	G 1/8	40	12.3	-	-	40	8	8	8.5	154	35.1

Diagrams

Flow rate characteristic

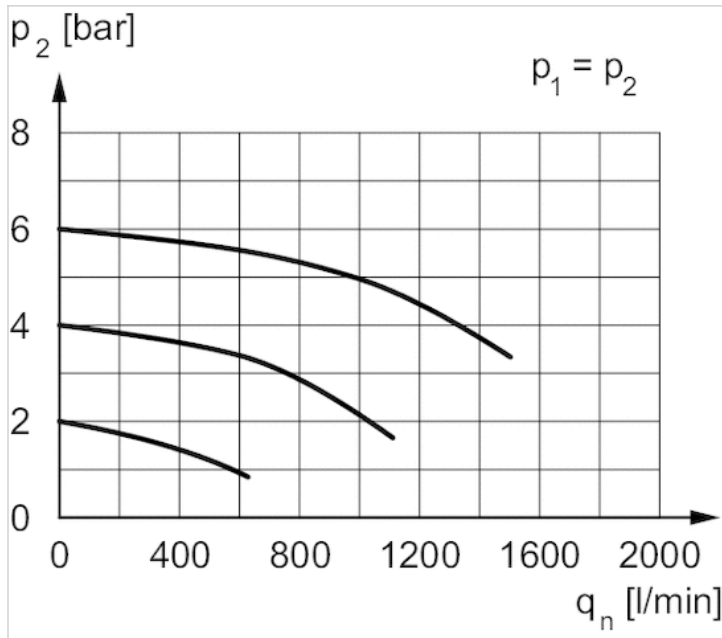

p_2 = secondary pressure q_n = nominal flow