

Ejector, Series EBS

- Thread connection
- electrical control, T-design
- with release valve
- with silencer
- vacuum switch electronic, adjustable

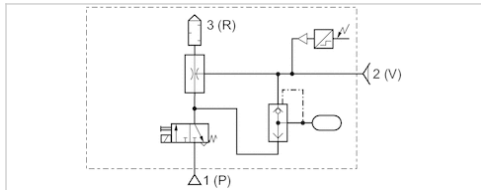

Type	Ejector
Version	electrical control, T-design
Activation	Electrically
vacuum switch	electronic, adjustable
Working pressure min./max.	3 ... 6 bar
Ambient temperature min./max.	0 ... 50 °C
Medium temperature min./max.	0 ... 50 °C
Medium	Compressed air
Max. particle size	5 µm
Oil content of compressed air	0 ... 1 mg/m ³
Protection class	IP40
Duty cycle according to DIN VDE 0580 standard	100 %
Hysteresis	2% of the final value, fixed
Precision (% of full scale value)	± 3 %
Repeatability (% of full scale value)	± 1 %
DC operating voltage	24 V
Voltage tolerance DC	- 5% / +10%
Power consumption Solenoid valve	1,3 W
Switching point	adjustable 0 ... 100%
Weight	See table

Technical data

Part No.		Type	Nozzle Ø	Compressed air connection
R412010176		EBS-ET-05-NC	0,5 mm	M5
R412010177		EBS-ET-07-NC	0,7 mm	M5
R412010178		EBS-ET-10-NO	1 mm	G 1/8
R412010179		EBS-ET-15-NO	1,5 mm	G 1/8
R412010180		EBS-ET-20-NO	2 mm	G 1/4
R412010181		EBS-ET-25-NO	2,5 mm	G 1/4

Part No.	Vacuum connection+	Max. vacuum level at p.opt	Max. suction capacity
R412010176	M5	84 %	7,5 l/min
R412010177	M5	85 %	16,8 l/min
R412010178	G 1/8	86 %	35 l/min
R412010179	G 1/8	84 %	71 l/min
R412010180	G 3/8	86 %	123 l/min
R412010181	G 3/8	84 %	223 l/min

Part No.	Air consumption at p.opt.	Sound pressure level intake effect
R412010176	14 l/min	53 dB
R412010177	24 l/min	65 dB
R412010178	48 l/min	59 dB
R412010179	118 l/min	71 dB
R412010180	208 l/min	68 dB
R412010181	320 l/min	70 dB

Part No.	Sound pressure level intake effect	Protection against overpressure (max.)	Weight	Fig.
R412010176	58 dB	5 bar	0,042 kg	Fig. 1
R412010177	68 dB	5 bar	0,042 kg	Fig. 1
R412010178	65 dB	5 bar	0,075 kg	Fig. 2
R412010179	71 dB	5 bar	0,075 kg	Fig. 2
R412010180	77 dB	5 bar	0,152 kg	Fig. 3
R412010181	78 dB	5 bar	0,152 kg	Fig. 3

Technical information

Note: All data refers to an ambient pressure of 1.013 bar and an ambient temperature of 20 °C .
The pressure dew point must be at least 15 °C under ambient and medium temperature and may not exceed 3 °C .

Technical information

Material	
Housing	Polyamide, fiber-glass reinforced
Seal	Acrylonitrile butadiene rubber
Nozzle	Aluminum
Silencers	Polyethylene
Pressure sensor	Polycarbonate

Dimensions

Fig. 1

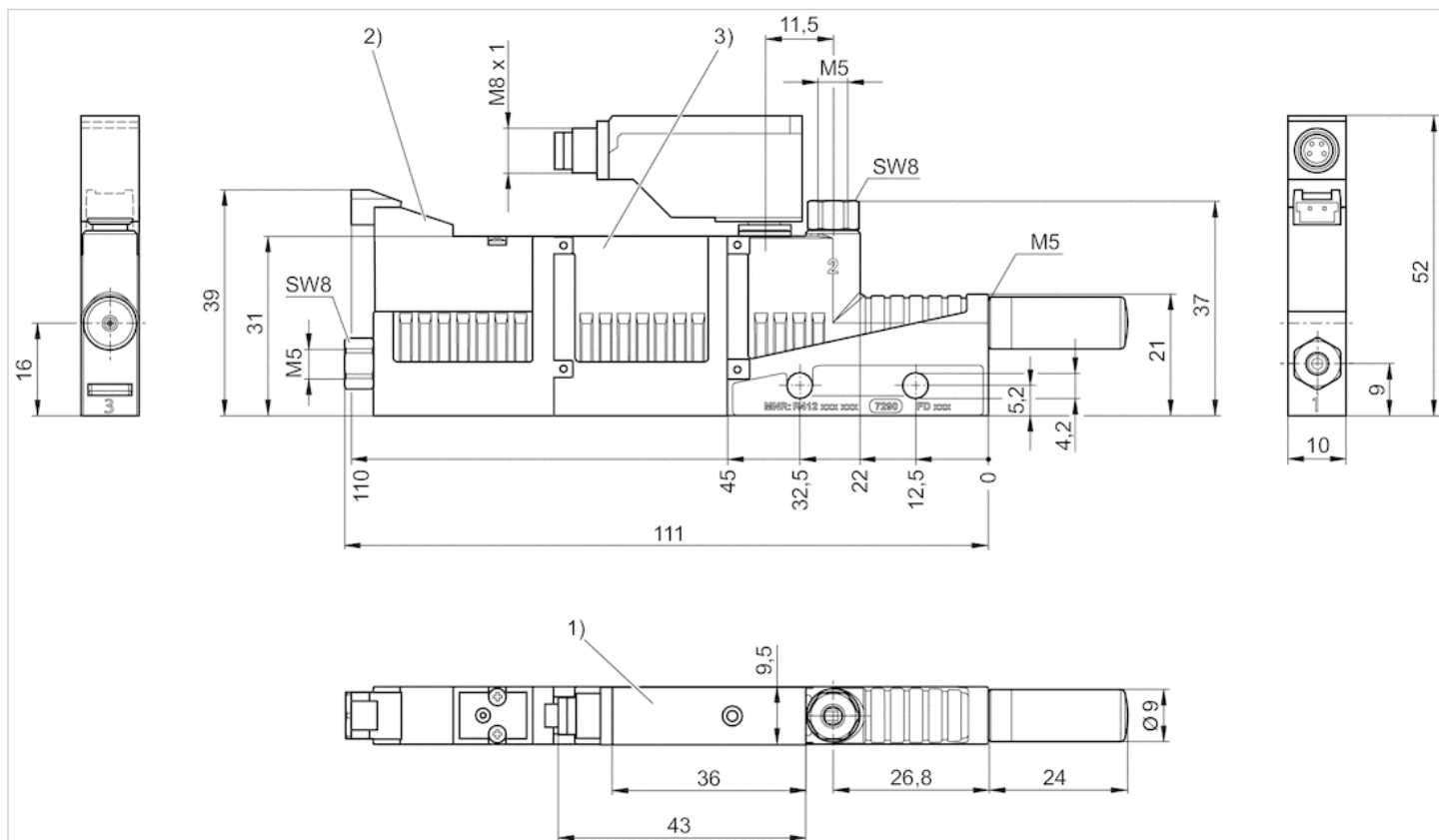

- 1) vacuum switch is rotatable and exchangeable
- 2) Solenoid valve for vacuum ON/OFF
- 3) Release valve from memory

Fig. 2

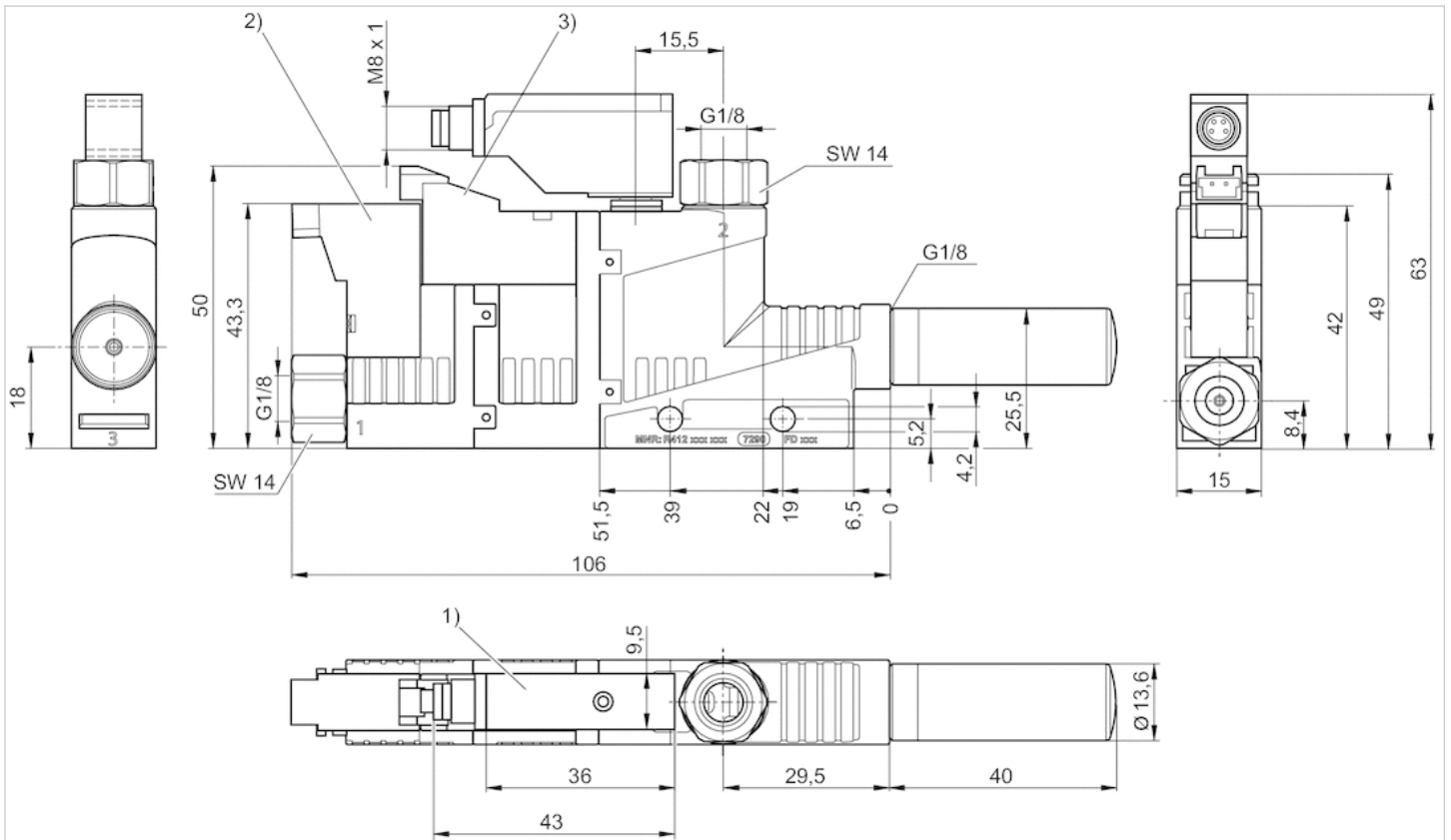

- 1) vacuum switch is rotatable and exchangeable
- 2) Solenoid valve for vacuum ON/OFF
- 3) Solenoid valve for release pulse

Fig. 3

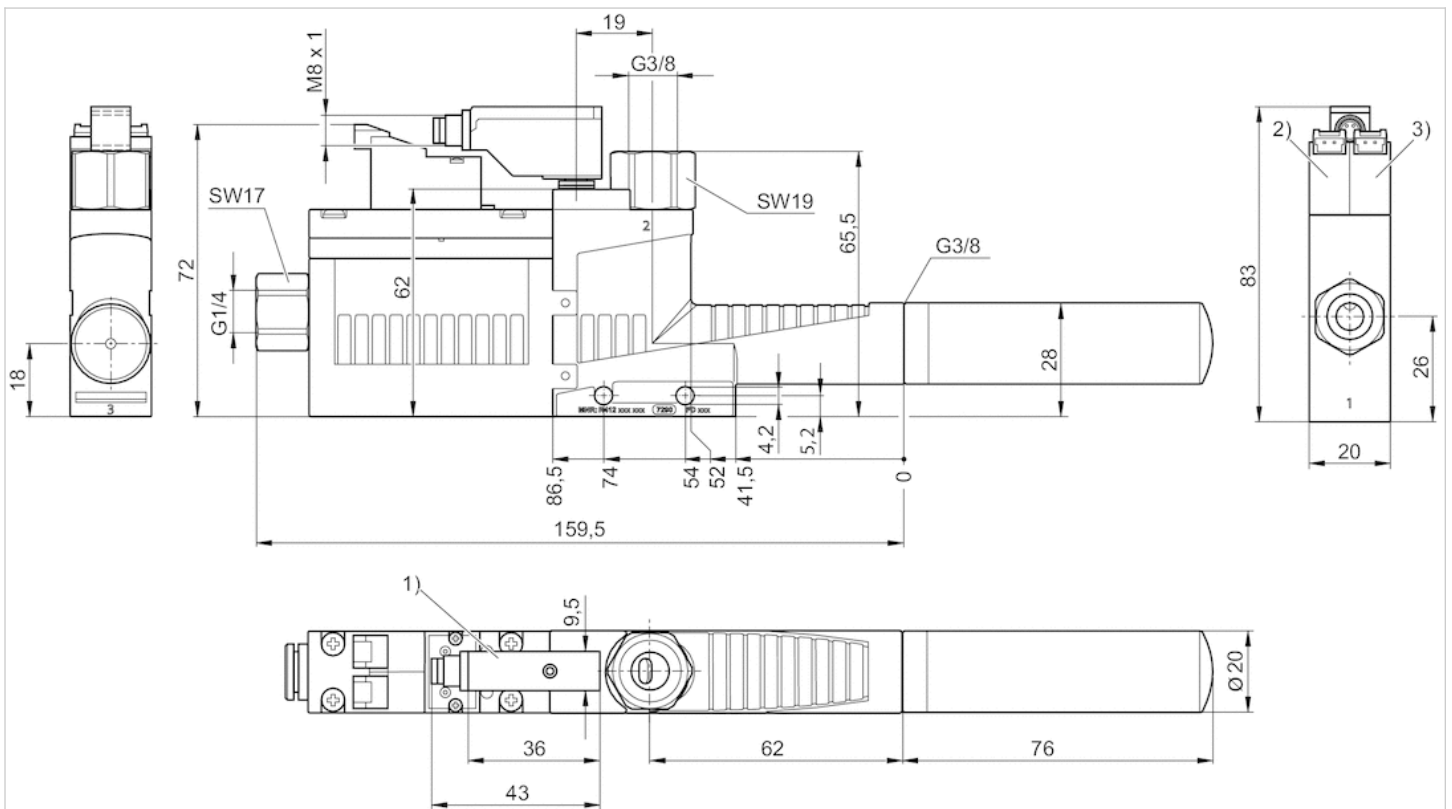

- 1) vacuum switch is rotatable and exchangeable
- 2) Solenoid valve for vacuum ON/OFF
- 3) Solenoid valve for release pulse

Diagrams

Vacuum p_2 depending on working pressure p_1

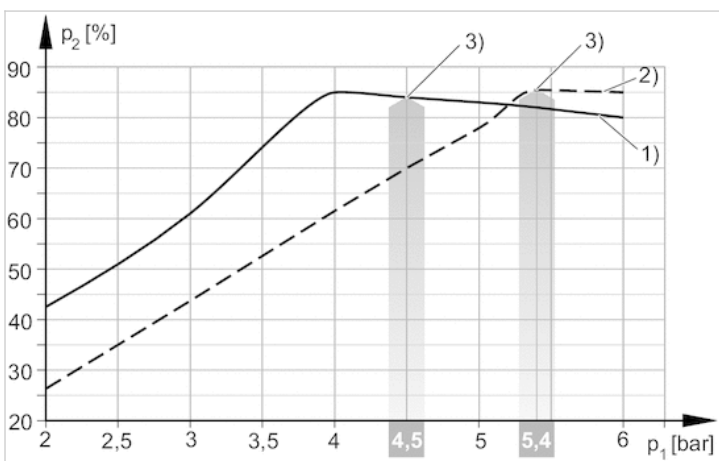

- 1) = \varnothing nozzle 0.5 mm
- 2) = \varnothing nozzle 0.7 mm
- 3) optimum working pressure

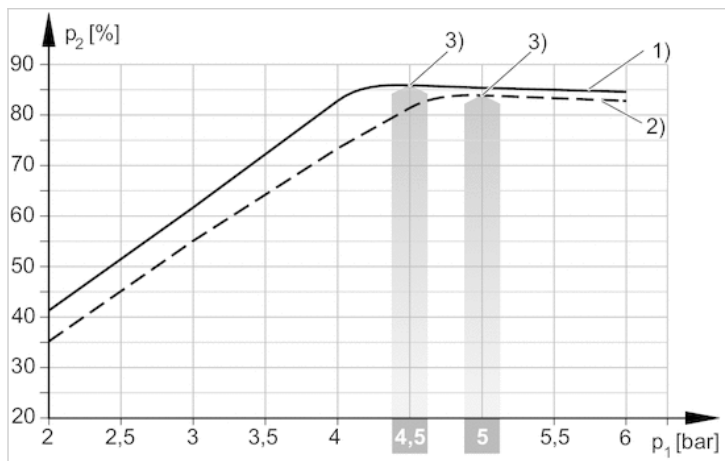

1) = Ø nozzle 1.0 mm 2) = Ø nozzle 1.5 mm
3) optimum working pressure

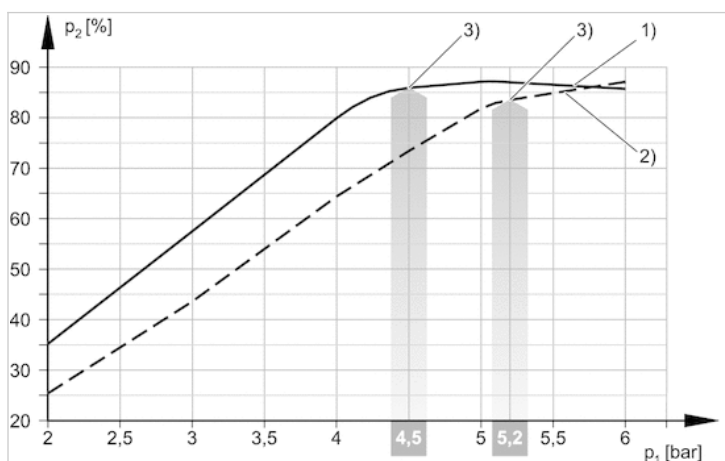

1) = Ø nozzle 2.0 mm 2) = Ø nozzle 2.5 mm
3) optimum working pressure

Suction capacity q_s depending on working pressure p₁

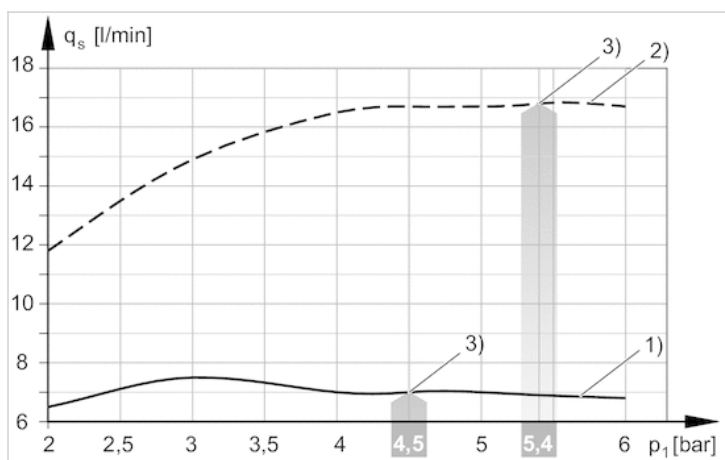

1) = Ø nozzle 0.5 mm 2) = Ø nozzle 0.7 mm
3) optimum working pressure

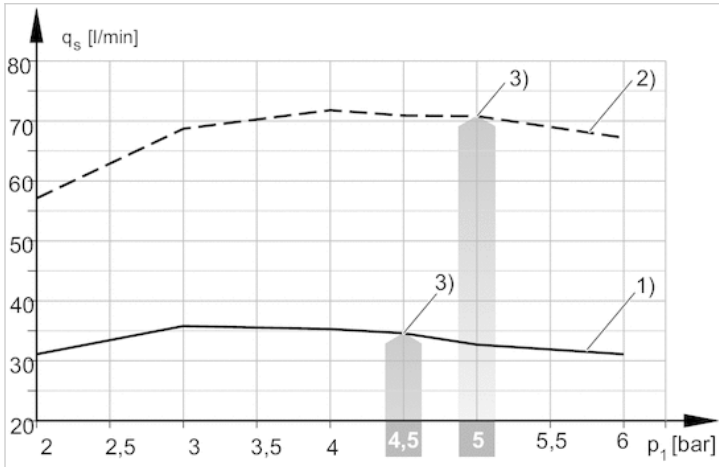

1) = \varnothing nozzle 1.0 mm 2) = \varnothing nozzle 1.5 mm
3) optimum working pressure

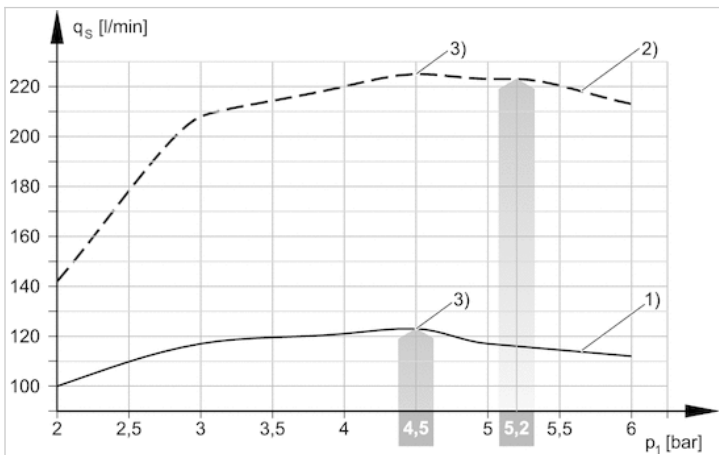

1) = \varnothing nozzle 2.0 mm 2) = \varnothing nozzle 2.5 mm
3) optimum working pressure

Evacuation time t_E depending on vacuum p_2 for 1 l volume (with optimal operating pressure)

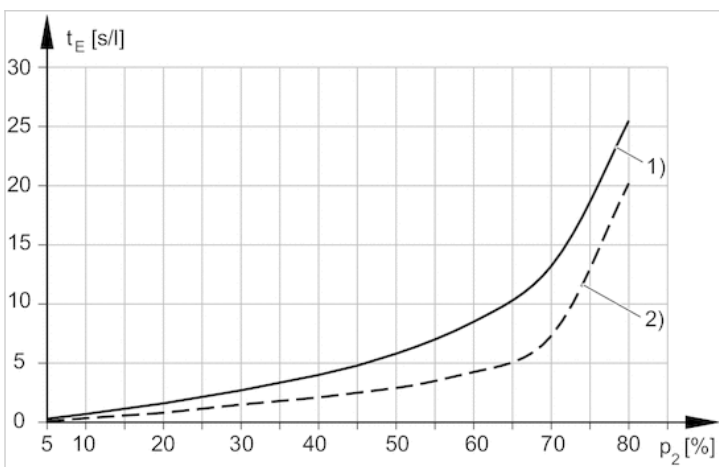

1) = \varnothing nozzle 0.5 mm 2) = \varnothing nozzle 0.7 mm

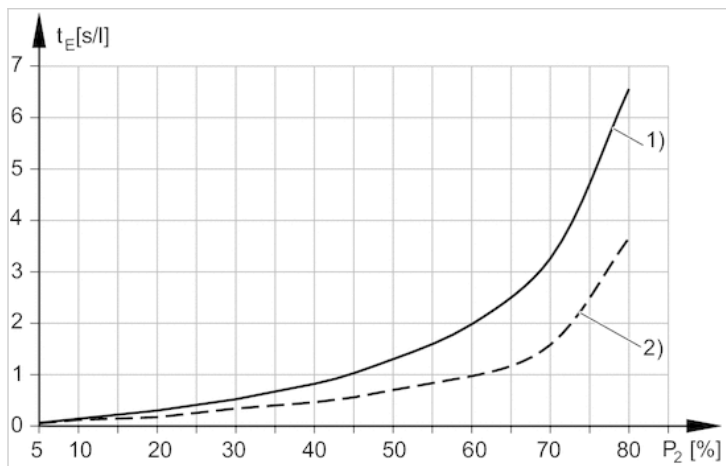

1) = Ø nozzle 1.0 mm 2) = Ø nozzle 1.5 mm

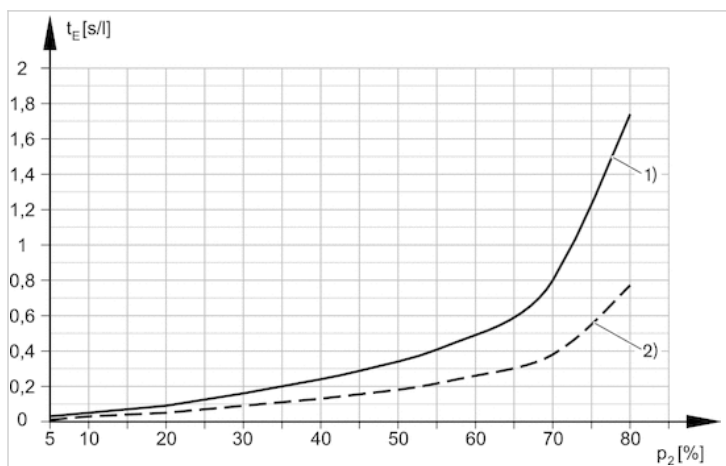

1) = Ø nozzle 2.0 mm 2) = Ø nozzle 2.5 mm

Air consumption q_v depending on working pressure p_1

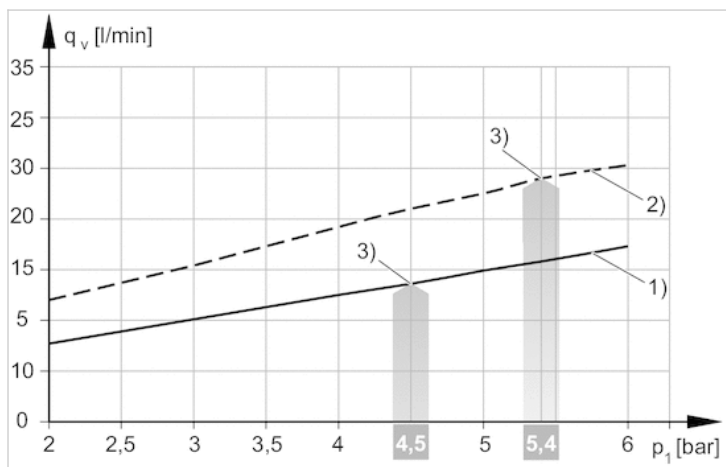

1) = Ø nozzle 0.5 mm 2) = Ø nozzle 0.7 mm
3) optimum working pressure

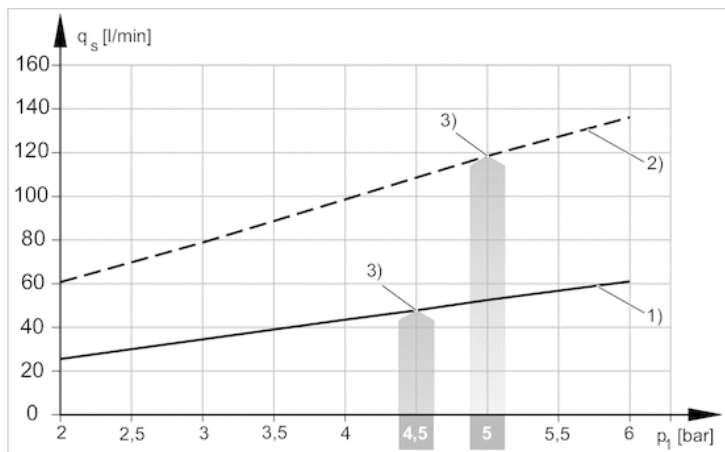

1) = Ø nozzle 1.0 mm 2) = Ø nozzle 1.5 mm
3) optimum working pressure

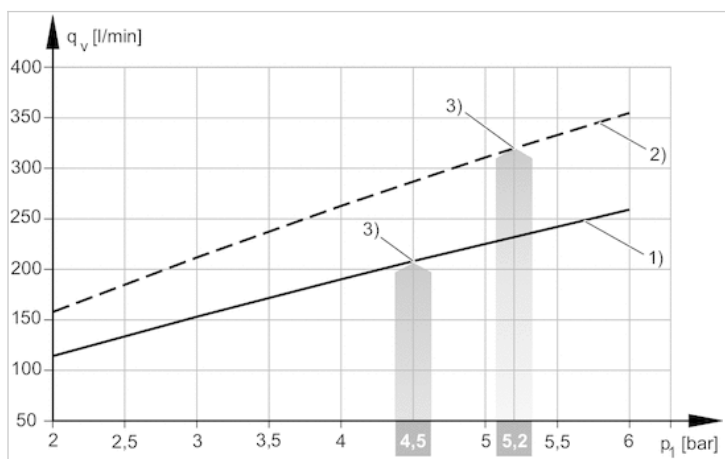

1) = Ø nozzle 2.0 mm 2) = Ø nozzle 2.5 mm
3) optimum working pressure