

Compact cylinder ISO 21287, Series CCI

- Ø 16 mm
- Ports M5
- double-acting
- with magnetic piston
- Cushioning elastic
- Piston rod Internal thread
- Piston rod non-rotating, with front plate



Standards	ISO 21287
Compressed air connection	Internal thread
Working pressure min./max.	1 ... 10 bar
Ambient temperature min./max.	-20 ... 80 °C
Medium temperature min./max.	-20 ... 80 °C
Medium	Compressed air
Max. particle size	50 µm
Oil content of compressed air	0 ... 5 mg/m ³
Pressure for determining piston forces	6.3 bar

Technical data

Piston Ø Piston rod thread Ports Piston rod Ø	16 mm M4 M5 8 mm	20 mm M6 M5 10 mm	25 mm M6 M5 10 mm	32 mm M8 G 1/8 12 mm	40 mm M8 G 1/8 12 mm	50 mm M10 G 1/8 16 mm
Stroke 5	R422001262	R422001263	R422001264	R422001265	R422001266	R422001267
10	R422001272	R422001273	R422001274	R422001275	R422001276	R422001277
15	R422001282	R422001283	R422001284	R422001285	R422001286	R422001287
20	R422001292	R422001293	R422001294	R422001295	R422001296	R422001297
25	R422001302	R422001303	R422001304	R422001305	R422001306	R422001307
30	R422001312	R422001313	R422001314	R422001315	R422001316	R422001317
40	R422001322	R422001323	R422001324	R422001325	R422001326	R422001327
50	R422001332	R422001333	R422001334	R422001335	R422001336	R422001337
60	R422001342	R422001343	R422001344	R422001345	R422001346	R422001347
80	-	-	-	R422001355	R422001356	R422001357
100	-	-	-	R422001365	R422001366	R422001367
125	-	-	-	R422001375	R422001376	R422001377
150	-	-	-	R422001385	R422001386	R422001387

Piston Ø Piston rod thread Ports Piston rod Ø	63 mm M10 G 1/8 16 mm	80 mm M12 G 1/8 20 mm	100 mm M12 G 1/8 25 mm
Stroke 5	R422001268	R422001269	R422001270
10	R422001278	R422001279	R422001280

Piston Ø Piston rod thread Ports Piston rod Ø	63 mm M10 G 1/8 16 mm	80 mm M12 G 1/8 20 mm	100 mm M12 G 1/8 25 mm
15	R422001288	R422001289	R422001290
20	R422001298	R422001299	R422001300
25	R422001308	R422001309	R422001310
30	R422001318	R422001319	R422001320
40	R422001328	R422001329	R422001330
50	R422001338	R422001339	R422001340
60	R422001348	R422001349	R422001350
80	R422001358	R422001359	R422001360
100	R422001368	R422001369	R422001370
125	R422001378	R422001379	R422001380
150	R422001388	R422001389	R422001390

Technical information

The pressure dew point must be at least 15 °C under ambient and medium temperature and may not exceed 3 °C .

The oil content of compressed air must remain constant during the life cycle.

Use only the approved oils from AVENTICS. Further information can be found in the "Technical information" document (available in the MediaCentre).

Impact energy	0,15 J	0,2 J	0,3 J	0,5 J	0,7 J	1 J	1,5 J
Weight 0 mm stroke	0,071 kg	0,119 kg	0,155 kg	0,303 kg	0,383 kg	0,626 kg	0,907 kg
Weight +10 mm stroke	0,019 kg	0,026 kg	0,03 kg	0,05 kg	0,06 kg	0,09 kg	0,107 kg
Stroke max.	300 mm	300 mm	300 mm	300 mm	300 mm	300 mm	300 mm

Piston Ø	80 mm	100 mm
Retracting piston force	2969 N	4639 N
Extracting piston force	3167 N	4948 N
Impact energy	1,8 J	2,5 J
Weight 0 mm stroke	1,46 kg	2,64 kg
Weight +10 mm stroke	0,136 kg	0,188 kg
Stroke max.	500 mm	500 mm

Technical information

Material	
Cylinder tube	Aluminum, anodized
Piston rod	Stainless steel
Front cover	Aluminum
End cover	Aluminum
Seal	Polyurethane
Front plate	Aluminum
Nut for piston rod	Steel, galvanized
Scraper	Polyurethane

Dimensions

Ø 16 mm ... 100 mm

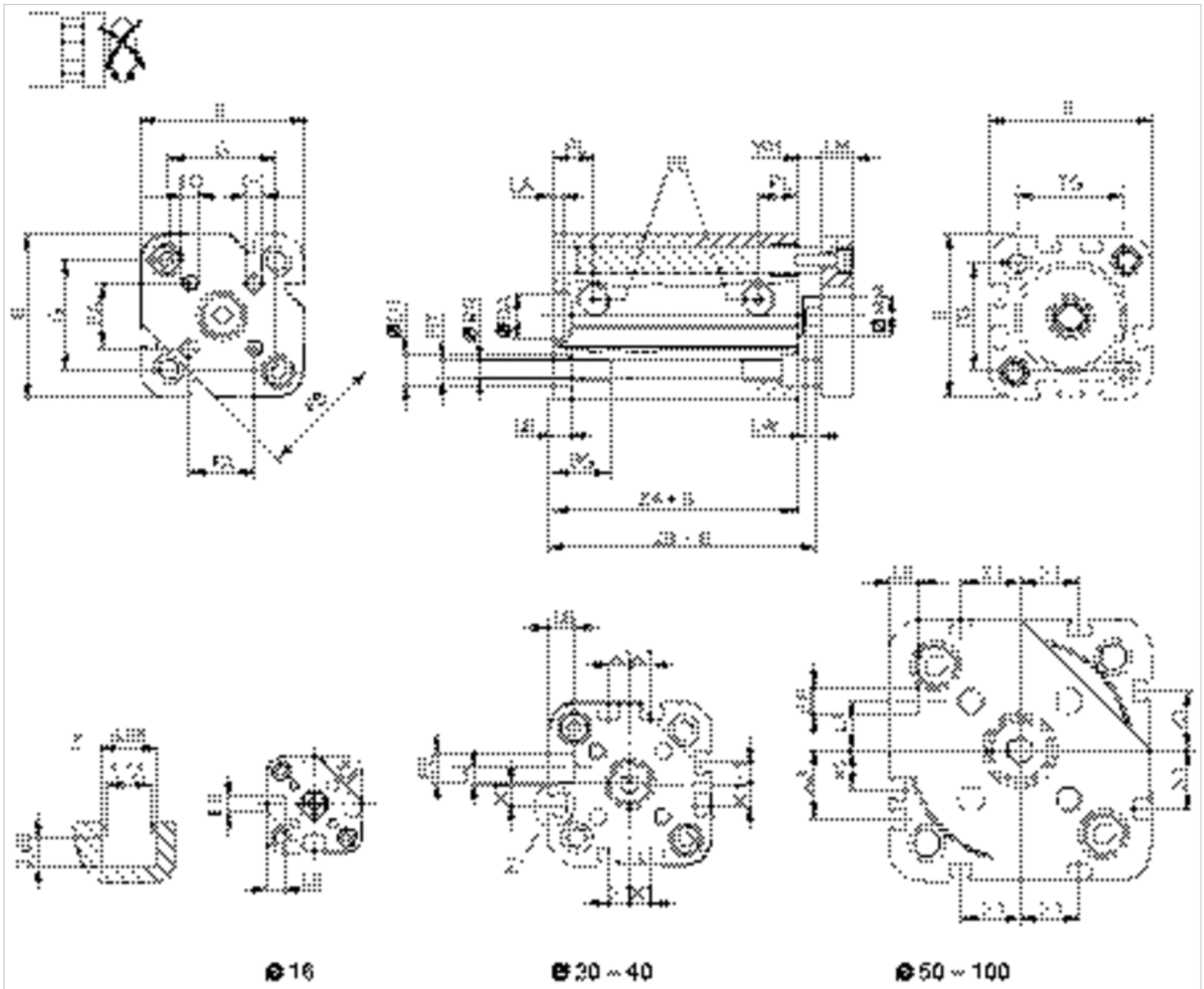

S = stroke
G = distance between the guide rods

Dimensions

Piston Ø	BC	BG	DA H11	DG H13	DT	E	EE	FA	FB	G	LA	LB	LE	LJ	LM	LW
16 mm	M3	15	10	3	6	29.3	M5	9,9 ±0,1	20	19	2.5	3.5	4.5	-	6	4
20 mm	M4	15.5	12	4	7.5	36.3	M5	12 ±0,1	24	25	2.5	4.5	4.5	4.5	8	4
25 mm	M5	15.5	12	5	8	40.3	M5	15,6 ±0,1	30	27	2.5	4.5	4.5	4	8	4
32 mm	M5	17	14	5	8.6	50	G 1/8	19,8 ±0,1	38	34	2.5	5	7.5	4.85	10	4.5
40 mm	M5	17	14	5	9.2	58	G 1/8	23,3 ±0,1	44	42	2.5	5	7.5	9.85	10	4.5
50 mm	M6	17	18	6	11	68.3	G 1/8	29,7 ±0,1	54	49	2.5	5	7.5	12	12	6
63 mm	M6	17	18	6	11	80	G 1/8	35,4 ±0,1	62	60	2.5	5	7.5	14.8	12	6
80 mm	M8	20	23	8	15	96	G 1/8	46 ±0,1	80	72	3	5	7.5	22	14	7
100 mm	M10	20	28	10	15	116	G 1/8	56,6 ±0,1	100	92	3	5	7.5	27	14	7

Piston Ø	MM f8	PL	RR	RT 6H	TG	WH	X1	X2	X3	ZA ±0,1	ZB
16 mm	8	8	3.3	M4	18	4,8 ±0,9	-	-	-	34.9	39,7 ±0,8
20 mm	10	10	4.2	M5	22	6,3 ±0,9	4.2	-	-	37.3	43,6 ±0,8
25 mm	10	10	4.2	M5	26	5,6 ±0,9	4.5	-	-	39	44,5 ±0,9
32 mm	12	12	5.1	M6	32.5	7,4 ±0,9	6.5	-	-	44	51,4 ±1
40 mm	12	12	5.1	M6	38	7,4 ±0,9	11	-	-	45	52,4 ±1
50 mm	16	12	6.7	M8	46.5	8,4 ±0,9	13	4	13	45.5	53,6 ±1
63 mm	16	12	6.7	M8	56.5	8,5 ±0,9	18	12	21	49	57,4 ±1
80 mm	20	14	8.5	M10	72	9,8 ±1	18	16.5	25.5	54.7	64,4 ±1
100 mm	25	16.5	8.5	M10	89	9,8 ±1	20	20	29	67	76,7 ±1

Diagrams

Maximum admissible lateral force static

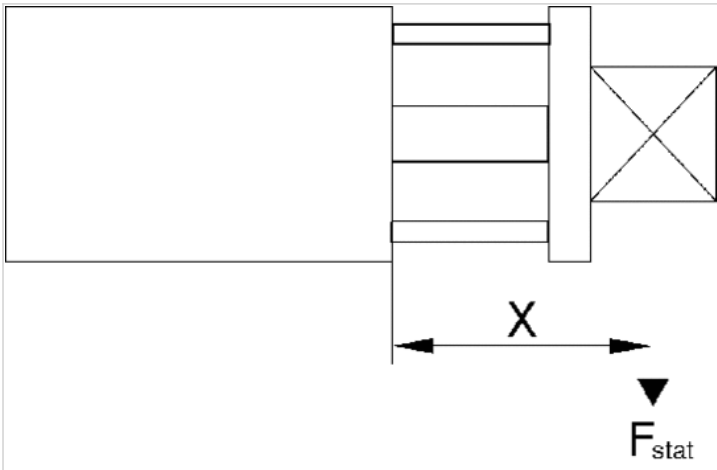

F_{stat} = static lateral force

X = distance between force application point and cylinder cover

Maximum admissible lateral force static

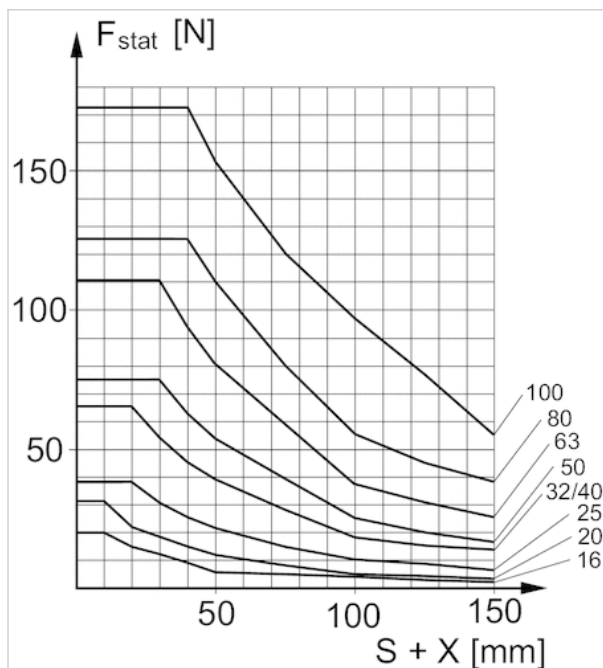

F_{stat} = static lateral force

X = distance between force application point and cylinder cover
S = stroke

Maximum admissible lateral force dynamic

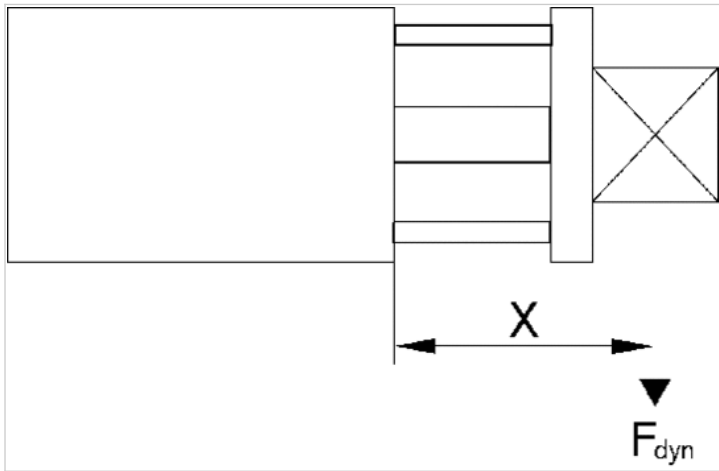

F_{dyn} = dynamic lateral force
X = distance between force application point and cylinder cover

Maximum admissible lateral force dynamic

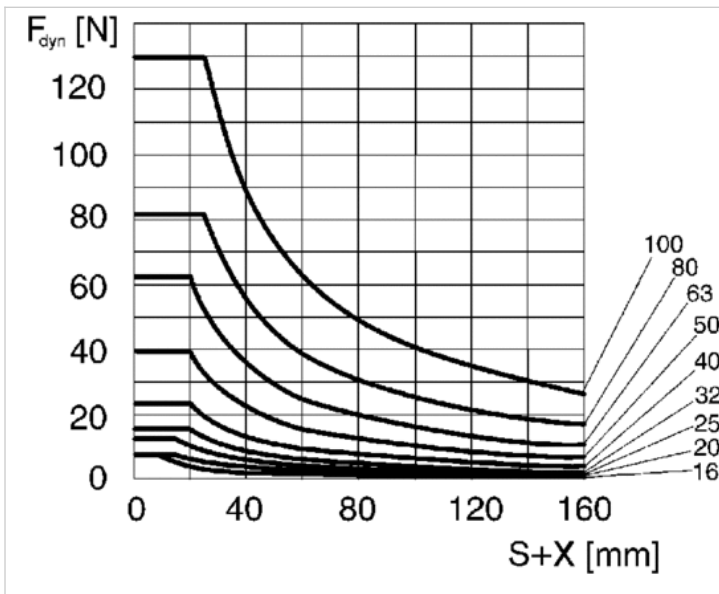

F_{dyn} = dynamic lateral force
X = distance between force application point and cylinder cover
S = stroke

Max. permissible torque

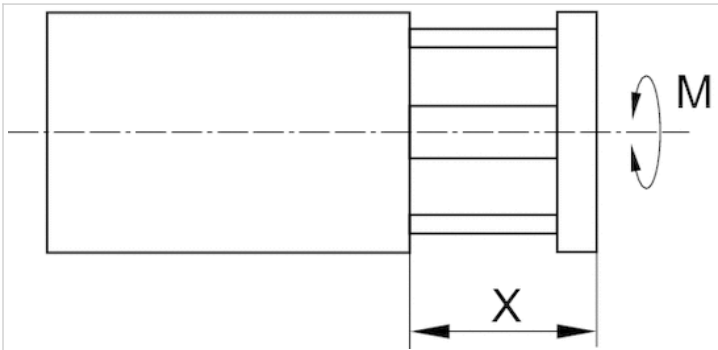

M = max. permissible torque
 X = distance between force application point and cylinder cover

Max. permissible torque

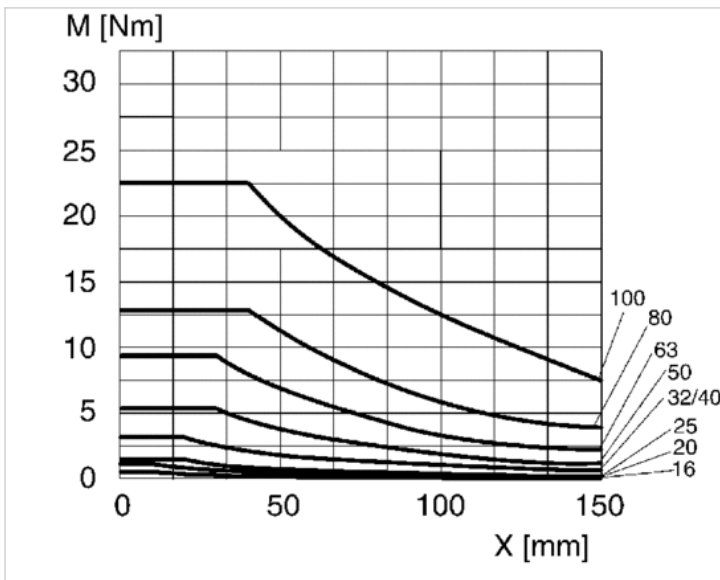

M = max. permissible torque
 X = spacing between torque contact surface and cylinder cover