

Filter pressure regulator, Series AS2-FRE

- G 1/4 G 3/8
- filter porosity 5 μm
- lockable
- for padlocks
- suitable for ATEX

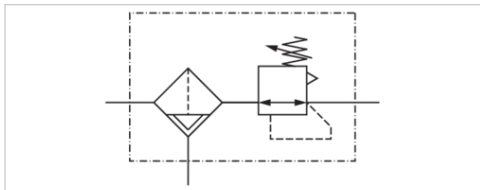

Version	1-in-1, Can be assembled into blocks
Parts	Filter pressure regulator
Mounting orientation	vertical
Certificates	suitable for ATEX
Working pressure min./max.	See table below
Ambient temperature min./max.	-10 ... 50 °C
Medium temperature min./max.	-10 ... 50 °C
Medium	Compressed air Neutral gases
Regulator type	Diaphragm-type pressure regulator
Regulator function	with relieving air exhaust
Adjustment range min./max.	See table below
Pressure supply	single
Filter reservoir volume	28 cm ³
Filter element	exchangeable
Condensate drain	See table below
Weight	See table below

Technical data

Part No.	Port	Flow	Working pressure min./max.	Adjustment range min./max.
		Qn		
R412006175	G 1/4	2100 l/min	1,5 ... 16 bar	0,5 ... 8 bar
R412006181	G 1/4	2100 l/min	1,5 ... 16 bar	0,5 ... 8 bar
R412006193	G 1/4	2100 l/min	1,5 ... 16 bar	0,5 ... 10 bar
R412006236	G 1/4	2100 l/min	1,5 ... 16 bar	0,5 ... 16 bar
R412006176	G 1/4	2100 l/min	1,5 ... 16 bar	0,5 ... 8 bar
R412006177	G 1/4	2100 l/min	0 ... 16 bar	0,5 ... 8 bar
R412006182	G 1/4	2100 l/min	1,5 ... 16 bar	0,5 ... 8 bar
R412006183	G 1/4	2100 l/min	0 ... 16 bar	0,5 ... 8 bar
R412006194	G 1/4	2100 l/min	1,5 ... 16 bar	0,5 ... 10 bar
R412006195	G 1/4	2100 l/min	0 ... 16 bar	0,5 ... 10 bar
R412006237	G 1/4	2100 l/min	1,5 ... 16 bar	0,5 ... 16 bar
R412006238	G 1/4	2100 l/min	0 ... 16 bar	0,5 ... 16 bar
R412006184	G 3/8	2600 l/min	1,5 ... 16 bar	0,5 ... 8 bar
R412006190	G 3/8	2600 l/min	1,5 ... 16 bar	0,5 ... 8 bar
R412006191	G 3/8	2600 l/min	1,5 ... 16 bar	0,5 ... 8 bar
R412006203	G 3/8	2600 l/min	1,5 ... 16 bar	0,5 ... 10 bar
R412006239	G 3/8	2600 l/min	1,5 ... 16 bar	0,5 ... 16 bar
R412006185	G 3/8	2600 l/min	1,5 ... 16 bar	0,5 ... 8 bar

Part No.	Port	Flow	Working pressure min./max.	Adjustment range min./max.
		Qn		
R412006186	G 3/8	2600 l/min	0 ... 16 bar	0,5 ... 8 bar
R412006192	G 3/8	2600 l/min	0 ... 16 bar	0,5 ... 8 bar
R412006204	G 3/8	2600 l/min	1,5 ... 16 bar	0,5 ... 10 bar
R412006205	G 3/8	2600 l/min	0 ... 16 bar	0,5 ... 10 bar
R412006240	G 3/8	2600 l/min	1,5 ... 16 bar	0,5 ... 16 bar
R412006241	G 3/8	2600 l/min	0 ... 16 bar	0,5 ... 16 bar

Part No.	Condensate drain	Reservoir	Protective guard	Weight
R412006175	semi-automatic, open without pressure	Polycarbonate	Polyamide	0,304 kg
R412006181	semi-automatic, open without pressure	Die cast zinc	-	0,537 kg
R412006193	semi-automatic, open without pressure	Polycarbonate	Polyamide	0,304 kg
R412006236	semi-automatic, open without pressure	Polycarbonate	Polyamide	0,304 kg
R412006176	fully automatic, open without pressure	Polycarbonate	Polyamide	0,347 kg
R412006177	fully automatic, closed without pressure	Polycarbonate	Polyamide	0,347 kg
R412006182	fully automatic, open without pressure	Die cast zinc	-	0,66 kg
R412006183	fully automatic, closed without pressure	Die cast zinc	-	0,589 kg
R412006194	fully automatic, open without pressure	Polycarbonate	Polyamide	0,347 kg
R412006195	fully automatic, closed without pressure	Polycarbonate	Polyamide	0,347 kg
R412006237	fully automatic, open without pressure	Polycarbonate	Polyamide	0,347 kg
R412006238	fully automatic, closed without pressure	Polycarbonate	Polyamide	0,347 kg
R412006184	semi-automatic, open without pressure	Polycarbonate	Polyamide	0,347 kg
R412006190	semi-automatic, open without pressure	Die cast zinc	-	0,523 kg
R412006191	semi-automatic, open without pressure	Die cast zinc	-	0,655 kg
R412006203	semi-automatic, open without pressure	Polycarbonate	Polyamide	0,523 kg
R412006239	semi-automatic, open without pressure	Polycarbonate	Polyamide	0,523 kg
R412006185	fully automatic, open without pressure	Polycarbonate	Polyamide	0,347 kg
R412006186	fully automatic, closed without pressure	Polycarbonate	Polyamide	0,347 kg
R412006192	fully automatic, closed without pressure	Die cast zinc	-	0,575 kg
R412006204	fully automatic, open without pressure	Polycarbonate	Polyamide	0,655 kg
R412006205	fully automatic, closed without pressure	Polycarbonate	Polyamide	0,575 kg
R412006240	fully automatic, open without pressure	Polycarbonate	Polyamide	0,655 kg
R412006241	fully automatic, closed without pressure	Polycarbonate	Polyamide	0,575 kg

Nominal flow Qn with secondary pressure p2 = 6 bar at $\Delta p = 1$ bar

Order pressure gauge separately, Suitable for use in Ex zones 1, 2, 21, 22

Technical information

The pressure dew point must be at least 15 °C under ambient and medium temperature and may not exceed 3 °C .

Note: Polycarbonate reservoirs are susceptible to solvents, supplementary information can be found at "Customer information".

Suitable for use in Ex zones 1, 2, 21, 22

A change in the flow direction (from air supply on the left to air supply on the right) occurs by rotating installation by 180° about the vertical axis. Please see the operating instructions for further details.

Also suitable for separation of fluid oil or water due to the design.

Max. residual oil content acc. to ISO 8573-1 at the outlet 10 mg/m³

Technical information

Material	
Housing	Polyamide
Front plate	Acrylonitrile butadiene styrene
Seals	Acrylonitrile butadiene rubber
Threaded bushing	Die cast zinc
Reservoir	Polycarbonate Die cast zinc
Protective guard	Polyamide
Filter insert	Polyethylene

Dimensions

Dimensions

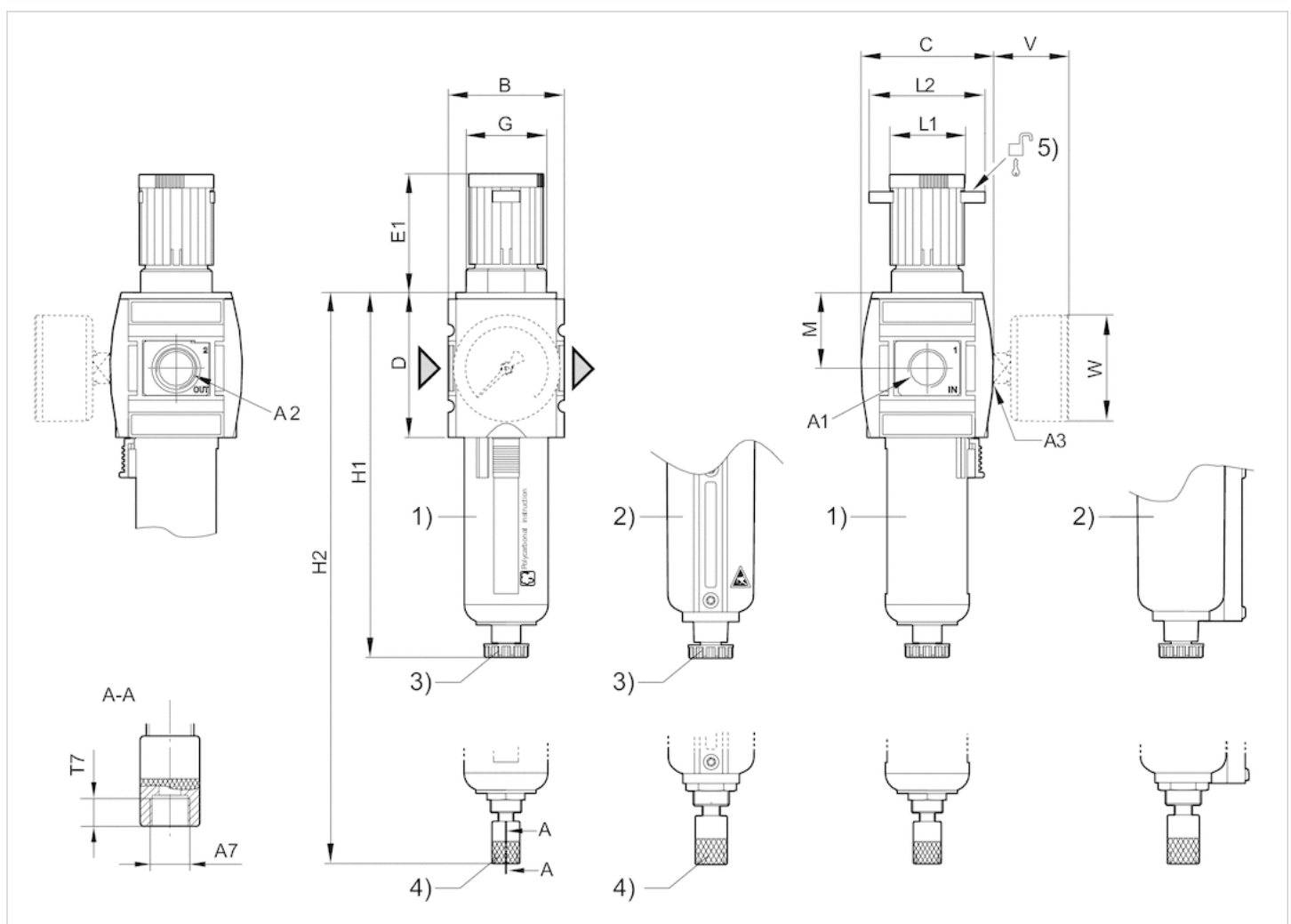

A1 = input A2 = output A3 = pressure gauge connection

A7 = condensate drain

1) Plastic reservoir and protective guard with window

2) Metal reservoir

3) Semi-automatic condensate drain

4) Fully automatic condensate drain

5) Mounting option for padlocks; max. shackle Ø 8

Dimensions in mm

A1	A2	A3	A7	B	C	D	E1	G	H1	H2	L1	L2	M	T7	V	W
G 1/4	G 1/4	G 1/4	G 1/8	52	59	65	57.9	M36x1,5	163.5	--	34	54	34	8.5	37	50
G 1/4	G 1/4	G 1/4	G 1/8	52	59	65	57.9	M36x1,5	--	180.5	34	54	34	8.5	37	50
G 3/8	G 3/8	G 1/4	G 1/8	52	59	65	57.9	M36x1,5	163.5	--	34	54	34	8.5	37	50
G 3/8	G 3/8	G 1/4	G 1/8	52	59	65	57.9	M36x1,5	--	180.5	34	54	34	8.5	37	50
G 3/8	G 3/8	G 1/4	G 1/8	52	59	65	57.9	M36x1,5	163.5	--	34	54	34	8.5	37	50
G 3/8	G 3/8	G 1/4	G 1/8	52	59	65	57.9	M36x1,5	--	180.5	34	54	34	8.5	37	50

Diagrams

Flow rate characteristic

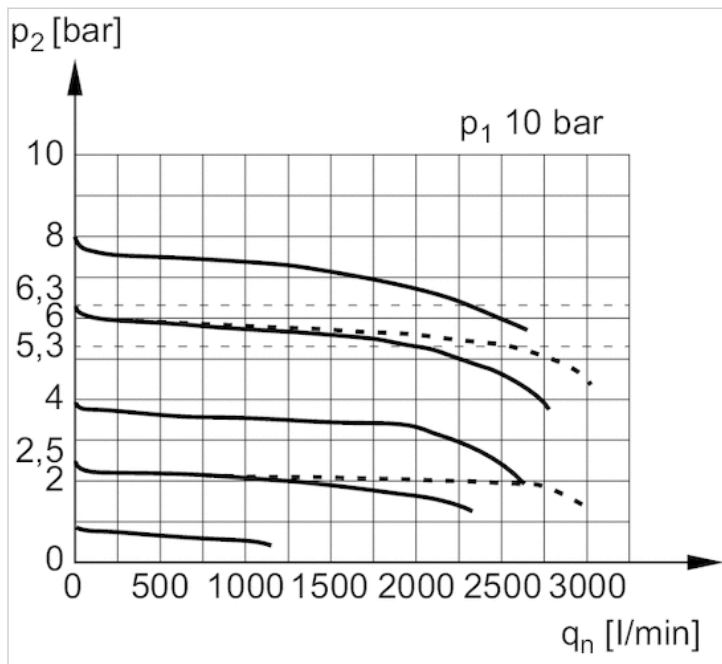

p_1 = Working pressure p_2 = Secondary pressure q_n = Nominal flow